

locktronics

Simplifying Electricity

Advanced electrical principles – AC



CP8749

MATRIX
www.matrixmultimedia.com

Copyright © 2009 Matrix Multimedia Limited

Worksheet 1 - Inductors	3
Worksheet 2 - Capacitors	5
Worksheet 3 - Inductor and Resistor in Series	7
Worksheet 4 - Capacitor and Resistor in Series	9
Worksheet 5 - Series LCR circuit	11
Worksheet 6 - Inductor and Resistor in Parallel	13
Worksheet 7 - Capacitor and Resistor in Parallel	15
Worksheet 8 - Parallel LCR circuit	17
Worksheet 9 - Q Factor	19
Instructors' Guide	22

Worksheet 1

Inductors



Resistors oppose electric currents. Inductors oppose *changes* to electric currents, but the mechanism is different.

An electric current flowing in the inductor, sets up a magnetic field. Increasing the current means increasing the magnetic field, and that takes energy from the current, opposing the increase. Reducing the current means reducing the magnetic field, and that releases energy which tries to maintain the current.

Inductors behave rather like flywheels on a rotating shaft. Their angular momentum tries to keep the shaft rotating at the same speed. When the shaft starts to slow down, the stored energy in the flywheel tries to keep it going. When the shaft tries to speed up, the flywheel requires energy to speed it up, and so the flywheel seems to resist the change.

Over to you:

Connect a 47mH inductor in series with the AC power supply, as shown in the circuit diagram.

Use enough connecting links so that the current can be measured at point **A**.

The photograph shows one way to build the circuit.

Set the AC power supply to output a frequency of 50Hz.

Remove the connecting link at **A**, and connect a multimeter, set to read up to 20mA **AC**, in its place. Record the current flowing at point **A** in the table.

Remove the multimeter and replace link **A**.

Set up the multimeter to read **AC** voltages of up to 20V and connect it in parallel with the inductor.

Record the voltage in the table.

Now change the power supply frequency to 100Hz and repeat the measurements. Record them in the table.

Do the same for frequencies of 500Hz and 1kHz (1,000Hz). Again, record these measurements in the table.

The table allows you to take two sets of measurements at each frequency to improve the accuracy of your results.

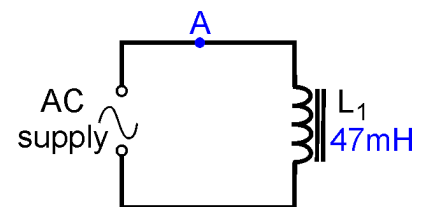

Frequency	Current I	Voltage V
50Hz		
100Hz		
500Hz		
1kHz		

Worksheet 1

Inductors



So what?

- Resistors behave in a straightforward way, spelled out by Ohm's Law. If you double the current through the resistor, you double the voltage dropped across it, and so on. The ratio of voltage to current is called resistance.
- Inductors are more complicated. If you double the *rate of change* of current through the inductor, you double the voltage dropped across it, and so on. The ratio of voltage to rate of change of current is called **inductance L**.
- The higher the frequency of the AC, the faster the current changes, and so the greater the voltage drop across the inductor. In other words, the voltage dropped depends on the frequency of the AC supply. This is **not** the case with pure resistors, where the frequency has no effect.
- We describe this behaviour in terms of the **(inductive) reactance, X_L** , defined, in the same way as resistance, as **$X_L = V / I$** . As a result, the units of reactance are ohms.
- The inductive reactance measures the opposition of the inductor to changing current. The higher the frequency, **f**, the greater the change in current. In fact, the formula for inductive reactance is:

$$X_L = 2 \pi f L$$

- Using your measurements, calculate the X_L , from the formula:

$$X_L = V / I$$

and compare that with the value calculated using

$$X_L = 2 \pi f L \quad \text{where } L = 47\text{mH}$$

- Carry out those calculations and fill in the following table with your results:

Frequency	Inductive reactance $X_L = V / I$	Inductive reactance $X_L = 2 \pi f L$
50Hz		
100Hz		
500Hz		
1kHz		



For your records:

The opposition of an inductor to changing currents is called inductive reactance, X_L , given by the formula: $X_L = 2 \pi f L$ where f is the frequency of the AC signal, and L is the inductance of the inductor.

It can also be obtained from the formula $X_L = V / I$, where V and I are rms voltage and current respectively.

Inductance is measured in a unit called the henry, (H) and reactance in ohms.

Complete the following:

When the AC frequency is doubled, the inductive reactance is

Worksheet 2

Capacitors



An electric current sets up a **magnetic** field inside an inductor. This then oppose changes to electric *currents*.

An electric current sets up an **electric** field across the plates of a capacitor. This opposes changes to the *voltage* applied to the capacitor. Before the voltage can increase, electrons must flow onto the plates of the capacitor, increasing the electric field. This requires energy. When the voltage tries to decrease, electrons flow off the plates, reducing the electric field. These electrons try to maintain the voltage across the capacitor.

Capacitors behave rather like buckets in a water circuit. They must fill up before any water flows anywhere else in the circuit. When the flow of water starts to fall, excess water flows from the bucket, trying to maintain the flow.

Over to you:

Connect a $1\mu\text{F}$ capacitor in series with the AC power supply, as shown in the circuit diagram.

Use enough connecting links so that the current can be measured at point **A**.

Set the AC power supply to output a frequency of 50Hz.

Remove the connecting link at **A**, and connect a multimeter, set to read up to 20mA AC, in its place. Record the current flowing at point **A** in the table.

Remove the multimeter and replace link **A**.

Set up the multimeter to read AC voltages of up to 20V and connect it in parallel with the capacitor.

Record the voltage in the table.

Now change the power supply frequency to 100Hz and repeat the measurements. Record them in the table.

Do the same for frequencies of 500Hz and 1kHz (1,000Hz). Again, record these measurements in the table.

As before, the table allows you to take two sets of measurements at each frequency to improve the accuracy of you results.

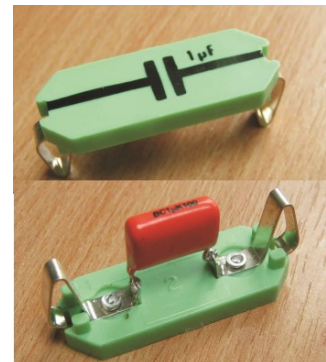
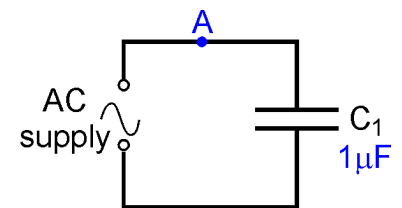

Frequency	Current I	Voltage V
50Hz		
100Hz		
500Hz		
1kHz		

Worksheet 2

Capacitors

So what?

- With resistors, when you double the *current* through the resistor, you double the voltage dropped across it, and so on. With inductors, when you double the rate of change of *current* through the inductor, you double the voltage dropped across it, and so on.
- Capacitors oppose a changing voltage. The faster the rate of change of *voltage*, the greater the current that must flow to charge or discharge the capacitor. The higher the frequency of the AC, the faster the *voltage* changes, and so the greater the current flowing in the circuit. In other words, the current depends on the frequency of the AC supply.
- We describe this behaviour in terms of the **capacitive reactance**, X_C , defined, in the same way as resistance, as $X_C = V / I$. As before, the units of reactance are ohms.
- The capacitive reactance measures the opposition of the capacitor to changing current. The higher the frequency, f , the greater the change in voltage, and the greater the current flow. The formula for capacitive reactance is: $X_C = 1 / (2 \pi f C)$
- Capacitors are very much a mirror image of inductors. As the frequency of the AC supply increases, an inductor offers more opposition, (i.e. the inductive reactance increases, and the current decreases) whereas a capacitor offers less opposition, (i.e. the capacitive reactance decreases, and the current increases).
- Using your measurements, calculate the X_C , using both :

$$X_C = V / I \quad \text{and} \quad X_C = 1 / (2 \pi f C) \quad \text{where } C = 1 \mu\text{F}$$
- Carry out those calculations and fill in the following table with your results:

Frequency	Capacitive reactance $X_C = V / I$	Capacitive reactance $X_C = 1 / (2 \pi f C)$
50Hz		
100Hz		
500Hz		
1kHz		



For your records:

The opposition of a capacitor to changing voltage is called capacitive reactance, X_C , given by the formula: $X_C = 1 / (2 \pi f C)$ where f is the frequency of the AC signal, and C is the capacitance of the capacitor.

It can also be obtained from the formula $X_C = V / I$, where V and I are rms voltage and current respectively.

Capacitance is measured in farads (F), though, in practice, this unit is too large.

Most capacitors have values given in microfarads (μF).

Complete the following:

When the AC frequency is doubled, the capacitive reactance is

Worksheet 3

Inductor and Resistor in Series



When an inductor and a resistor are connected in series, the pair act as a voltage divider, but with an important difference - the way they share the AC voltage changes with the frequency of the AC supply.

It is known as a series L-R circuit. As it is a series circuit, the same current flows everywhere.

The opposition to the current comes in two forms, the resistance of the resistor, which is independent of frequency, and the reactance of the inductor, which increases as the frequency increases. Together, these combine to make what is known as the impedance of the circuit.

Over to you:

Connect a 270Ω resistor, and a 47mH inductor in series with the AC supply, as shown in the circuit diagram.

Use enough connecting links so that the current can be measured at point **A**.

Set the AC power supply to output a frequency of 100Hz .

Remove the connecting link at **A**, and connect a multimeter, set to read up to 20mA AC, in its place. Record the current flowing at point **A** in the table.

Remove the multimeter and replace link **A**.

Set up the multimeter to read AC voltages of up to 20V . Connect it to measure the AC supply voltage, V_s , applied across the two components, and record it in the table.

Measure the voltage V_L , across the inductor, and then the voltage V_R , across the resistor. Record these voltages in the table.

Next, set the AC power supply to a frequency of 1kHz .

Repeat the measurements of current and the voltages across the two components, and record them in the table.

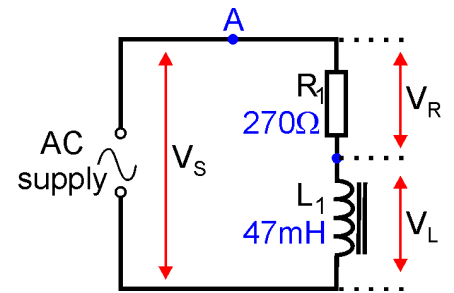

Measurement	AC frequency = 100Hz	AC frequency = 1kHz
Current at point A in mA		
Supply voltage V_s		
Voltage V_R across 270Ω resistor		
Voltage V_L across 47mH inductor		

Worksheet 3

Inductor and Resistor in Series



So what?

- You took measurements of current and voltage around the series L-R circuit. We will now calculate the same quantities. Then you can compare the two.
- There are two effects limiting the current - the resistance (270Ω) of the resistor, and the reactance X_L of the inductor.

At the first frequency, (100Hz): $X_L = 2 \pi f L$
 $= 2 \pi (100) \times (47 \times 10^{-3})$
 $= 29.5\Omega$

- We cannot just add together resistance and reactance, because of the phase shift involved. The voltage across the resistor is in phase with the current through it. The voltage across the inductor is 90° ahead of the current. We combine them using the formula for impedance, Z , which takes this phase shift into account: $Z = (R^2 + (X_L - X_C)^2)^{1/2}$

In this case, there is no capacitive reactance, and so:
 $Z = (R^2 + X_L^2)^{1/2}$
 $= ((270)^2 + (29.5)^2)^{1/2}$
 $= 271.61\Omega$

- We can use this value of impedance to calculate the current, using the formula:

$$I = V_S / Z \quad \text{where } V_S = \text{AC supply voltage}$$

Use your value of V_S here: $I = \dots\dots\dots$ mA

Using this value of I , the voltage across the resistor, V_R , is: $(V_R = I \times R)$
 $= \dots\dots\dots$ V

and the voltage across the inductor, V_L , is: $(V_L = I \times X_L)$
 $= \dots\dots\dots$ V

- Check these results against your measured values.
- At 1kHz**, notice how the share of the supply voltage changes. The higher frequency increases the reactance of the inductor. In fact, as the new frequency is 10 times bigger than the first, the reactance is 10 times bigger (i.e. 295.3 Ω.) Thus, the inductor takes a much bigger share of the supply voltage.
- You need to measure the AC supply voltage across the resistor and inductor again. The output impedance of the AC power supply itself will have an effect. Now that the impedance of the L-R circuit has increased, the output voltage of the AC supply may also have increased.
- Repeat the calculations at the new frequency, and check your results against the measured values.



For your records:

At a frequency f , the reactance of an inductor is: $X_L = 2 \pi f L$
 and the impedance of a L-R circuit is: $Z = (R^2 + X_L^2)^{1/2}$

The (rms) current is given by: $I = V_S / Z$ where V_S = (rms) AC supply voltage.

The resulting voltage across the resistor is $V_R = I \times R$ and across the inductor $V_L = I \times X_L$

When the rms value of supply voltage is used, all other currents and voltages will be rms.

When the peak value is used, all other currents and voltages will be peak values too.

Worksheet 4

Capacitor and Resistor in Series

w3a



When an inductor and a resistor are connected in series, the pair act as a voltage divider, but the way they share the AC voltage depends on the frequency of the AC supply.

The same is true when a capacitor and resistor are connected in series, but with an important difference - the reactance of the capacitor decreases as the frequency increases. For the inductor, reactance increases as the frequency increases.

This type of circuit is known as a series C-R circuit. As before, the same current flows in all parts of the circuit.

Over to you:

Connect a 270Ω resistor, and a $1\mu\text{F}$ capacitor in series with the AC supply, as shown in the circuit diagram.

Use enough connecting links so that the current can be measured at point **A**.

Set the AC power supply to output a frequency of 100Hz.

Remove the connecting link at **A**, and connect a multimeter, set to read up to 20mA AC, in its place. Record the current flowing at point **A** in the table.

Remove the multimeter and replace link **A**.

Set up the multimeter to read AC voltages of up to 20V. Connect it to measure the AC supply voltage, V_S , applied across the two components, and record it in the table.

Measure the voltage V_C , across the capacitor, and then the voltage V_R , across the resistor. Record these voltages in the table.

Next, set the AC power supply to a frequency of 1kHz.

Repeat the measurements of current and the voltages across the two components, and record them in the table.

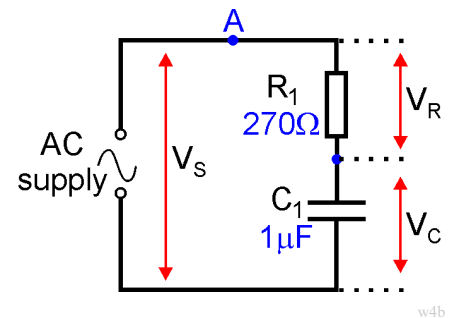

w4b

Measurement	AC frequency = 100Hz	AC frequency = 1kHz
Current at point A in mA		
Voltage V_R across 270Ω resistor		
Voltage V_C across $1\mu\text{F}$ capacitor		

Worksheet 4

Capacitor and Resistor in Series



So what?

- The treatment that follows mirrors that used for the previous worksheet. We calculate the quantities that you measured, so that you can then compare the two.
- The two effects limiting the current are - the resistance (270Ω) of the resistor, and the reactance X_C of the capacitor.

At the first frequency, (100Hz): $X_C = 1 / (2 \pi f C)$
 $= 1 / (2 \pi (100) \times (1 \times 10^{-6}))$
 $= 1591.5\Omega$

- The voltage across the resistor is in phase with the current through it. The voltage across the capacitor is 90° behind the current. The formula for impedance, Z, takes this phase shift into account:

$$Z = (R^2 + (X_L - X_C)^2)^{1/2}$$

In this case, there is no inductive reactance, and so:

$$Z = (R^2 + X_C^2)^{1/2}$$

$$= ((270)^2 + (1591.5)^2)^{1/2}$$

$$= 1614.3\Omega$$

- Use this value of impedance to calculate the current, using the formula:

$$I = V_S / Z \quad \text{where } V_S = \text{AC supply voltage}$$

(using your value of V_S here): $I = \dots\dots\dots$ mA

Hence the voltage across the resistor, V_R : $(V_R = I \times R)$
 $= \dots\dots\dots$ V

and the voltage across the capacitor, V_C : $(V_C = I \times X_C)$
 $= \dots\dots\dots$ V

- Check these results against your measured values.
- **At 1kHz**, notice how the share of the supply voltage changes this time. The **higher** frequency reduces the reactance of the capacitor. As the new frequency is 10 times **higher** than the first, the reactance is 10 times smaller (i.e. 159.2 Ω.) The capacitor takes a much lower share of the supply voltage at high frequencies.
- Once again, be warned - repeat the measurement of the AC supply voltage across the resistor and capacitor! The impedance of the C-R circuit has increased. The output voltage of the AC supply may also have increased.
- Repeat the calculations at the new frequency, and check your results against the measured values.



For your records:

At a frequency f, the reactance of a capacitor is: $X_C = 1 / (2 \pi f C)$
 and the impedance of a C-R circuit is: $Z = (R^2 + X_C^2)^{1/2}$

The (rms) current is given by: $I = V_S / Z$ where $V_S =$ (rms) AC supply voltage.

The resulting voltage across the resistor is $V_R = I \times R$ and across the capacitor $V_C = I \times X_C$

Worksheet 5

Series LCR circuit

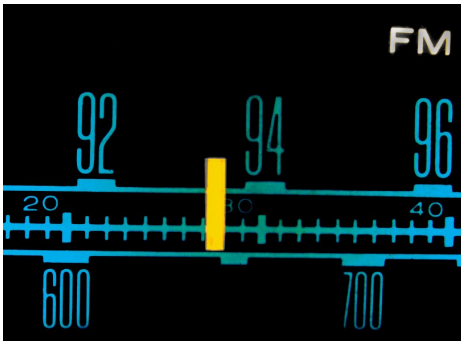

At this point, circuits become very interesting!

Inductors have a reactance that increases with frequency. Capacitors have a reactance that decreases with frequency. Resistors don't care about frequency.

A series LCR circuit has all three elements, though the resistance may be that of the wire used in the inductor, rather than of a discrete resistor.

One frequency, known as the resonant frequency, causes the circuit to behave in an extraordinary way!

Over to you:

Connect a 47mH inductor and a 1 μ F capacitor in series, as shown in the circuit diagram.

Set the AC power supply to output a frequency of **100Hz**.

Remove the connecting link at **A**, and connect a multimeter, set to read up to 20mA AC, in its place. Record the current flowing at point **A** in the table. Remove the multimeter and replace the link.

Set up the multimeter to read AC voltages of up to 20V. Connect it to measure the AC supply voltage, V_s , applied across the two components, and record it in the table.

Change the frequency to 200Hz, and repeat the measurements. Again record them in the table.

Do the same for the other frequencies listed, and complete the table.

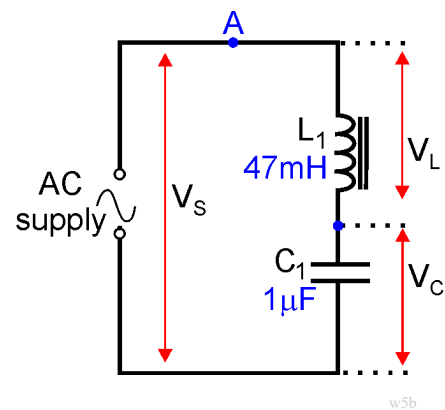

Frequency in Hz	AC supply voltage V_s in V	Current I at A in mA
100		
200		
300		
400		
500		
600		
700		
800		
900		
1000		

Worksheet 5

Series LCR circuit

So what?

- Your results table may not make it obvious what is happening, partly because the output impedance of the AC power supply will probably have an effect on output voltage. It will be clearer when we look at the impedance of the circuit.

- Complete the table, by calculating the impedance, Z , at different frequencies, using the formula:

$$Z = V_S / I$$

- At low frequencies, the capacitor has a high reactance, and the inductor a low reactance. As the frequency rises, the capacitor's reactance falls, but the inductor's reactance increases. There is one value of frequency, called the resonant frequency, where the combined effect of the two is a minimum.

Frequency in Hz	AC supply voltage V_S in V	Current I at A in mA	Impedance Z in $k\Omega$
100			
200			
300			
400			
500			
600			
700			
800			
900			
1000			

At this frequency, the impedance of the circuit is a **minimum**.

- Plot a graph of impedance against frequency, and use it to estimate the resonant frequency.

A typical frequency response curve is shown opposite.

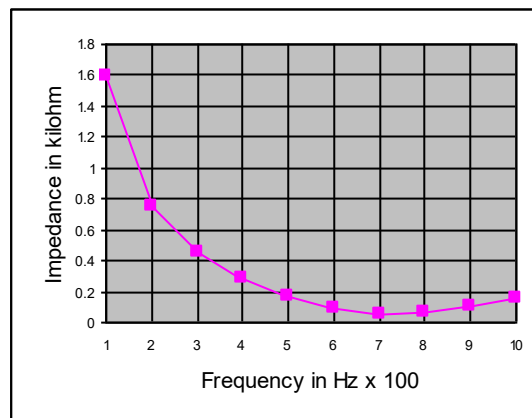

For your records:

For a series LCR circuit, the impedance is a minimum at the resonant frequency, f_R .

This can be calculated from the formula $f_R = 1 / 2 \pi \sqrt{L \times C}$

Worksheet 6

Inductor and Resistor in Parallel

When an inductor and a resistor are connected in parallel, the pair act as a current divider, which shares the AC current in a way that changes with the frequency of the AC supply.

Since the inductor and resistor are connected in parallel, they have the same voltage across them, but take a current which depends on resistance / reactance.

Over to you:

Connect a 270Ω resistor and a 47mH inductor in parallel with the AC supply, as shown.

Use enough connecting links so that the current can be measured at points **A**, **B** and **C**.

Set the AC power supply to output a frequency of 100Hz .

Remove the connecting link at **A**, and connect a multimeter, set to read up to 20mA AC, in its place. Record the current flowing at point **A** in the table. Remove the multimeter and replace link **A**.

Do the same for the currents flowing at points **B** and **C**.

Set up the multimeter to read AC voltages of up to 20V . Connect it to measure the AC supply voltage, V_S , applied across the two components, and record it in the table.

Next, set the AC power supply to a frequency of 1kHz .

Repeat the measurements of currents and the voltage across the two components, and record them in the table.

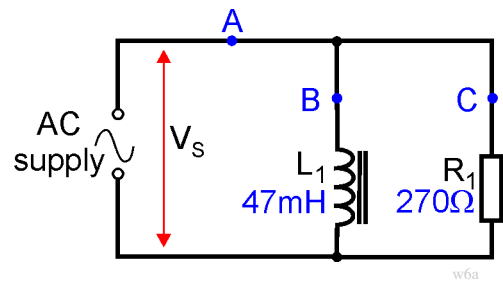

Measurement	AC frequency = 100Hz	AC frequency = 1kHz
Current at point A in mA		
Current at point B in mA		
Current at point C in mA		
Supply voltage V_S		

Worksheet 6

Inductor and Resistor in Parallel



So what?

- As before, we are going to calculate the quantities you measured, so that you can compare the two. Use your value of V_S to complete the calculations below.

At a frequency of 100Hz

- Resistance of resistor $R_1 = 270\Omega$,
and so the current through it, (at point **C**), $I_C = V_S / R = \dots\dots\dots / 270 = \dots\dots\dots$ A
- Reactance X_L of inductor L_1 is given by:

$$\begin{aligned} X_L &= 2 \pi f L \\ &= 2 \pi (100) \times (47 \times 10^{-3}) \\ &= 29.5\Omega \end{aligned}$$

and so the current through it, (at point **B**), $I_B = V_S / X_L = \dots\dots\dots / 29.5 = \dots\dots\dots$ A

- The current at **A**, I_A , is found by combining these currents, but not by simply adding them.

These currents are not in phase! The current, I_C , through the resistor is in phase with V_S . The current, I_B , through the inductor lags behind V_S by 90° .

The currents can be combined using the formula: $I_A^2 = I_B^2 + I_C^2$

or: $I_A = \sqrt{(I_B^2 + I_C^2)}$

- Use your results to the calculations above to calculate a value for I_A .
- Check these results against your measured values.

At a frequency of 1kHz

- Notice how the share of the *current* changes. The reactance of the inductor is 10 times bigger (i.e. 295.3Ω .) Thus, the inductor takes offers a much more difficult route for the current and so passes a much smaller current.
- You need to measure the AC supply voltage across the resistor and inductor again. The output impedance of the AC power supply itself will have an effect.
- Repeat the calculations at the new frequency, and check your results against the measured values.



For your records:

For a parallel combination of a resistor and inductor, the total current I_S is given by:

$$I_S^2 = I_L^2 + I_R^2$$

where I_L = current through inductor and I_R = current through resistor.

Using the AC version of Ohm's Law:

$$I_L = V_S / X_L \quad \text{and} \quad I_R = V_S / R$$

Worksheet 7

Capacitor and Resistor in Parallel

When a capacitor and a resistor are connected in parallel, they act as a current divider, sharing the AC current in a way that changes with the frequency of the AC supply.

However, in this case, when the supply frequency increases, the reactance of the capacitor *decreases*, making it an *easier* route for the current to flow through.

Over to you:

Connect a 270Ω resistor and a $1\mu\text{F}$ capacitor in parallel with the AC supply, as shown.

Use enough connecting links so that the current can be measured at points **A**, **B** and **C**.

Set the AC power supply to output a frequency of 100Hz.

Remove the connecting link at **A**, and connect a multimeter, set to read up to 20mA AC, in its place. Record the current flowing at point **A** in the table. Remove the multimeter and replace link **A**.

Do the same for the currents flowing at points **B** and **C**.

Set up the multimeter to read AC voltages of up to 20V. Connect it to measure the AC supply voltage, V_s , applied across the two components, and record it in the table.

Next, set the AC power supply to a frequency of 1kHz.

Repeat the measurements of currents and the voltage across the two components, and record them in the table.

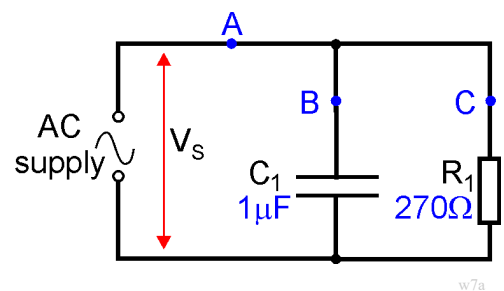

Measurement	AC frequency = 100Hz	AC frequency = 1kHz
Current at point A in mA		
Current at point B in mA		
Current at point C in mA		
Supply voltage V_s		

Worksheet 7

Capacitor and Resistor in Parallel



So what?

- As before, we are going to calculate the quantities you measured, so that you can compare the two. Use your value of V_S to complete the calculations below.

At a frequency of 100Hz

- Resistance of resistor $R_1 = 270\Omega$,
and so the current through it, (at point **C**), $I_C = V_S / R = \dots\dots\dots / 270 = \dots\dots\dots$ A
- Reactance X_C of capacitor C_1 is given by:

$$\begin{aligned} X_C &= 1 / 2 \pi f C \\ &= 2 \pi (100) \times (1 \times 10^{-6}) \\ &= 1591.5\Omega \end{aligned}$$

and so the current through it, (at point **B**), $I_B = V_S / X_C = \dots\dots\dots / 1591.5 = \dots\dots\dots$ A

- Again, these currents are not in phase. The current, I_C , through the resistor is in phase with V_S . The current, I_B , through the capacitor leads V_S by 90° .

The current at **A**, I_A , is found by combining these currents, using the formula:

$$\begin{aligned} I_A^2 &= I_B^2 + I_C^2 \\ \text{or: } I_A &= \sqrt{I_B^2 + I_C^2} \end{aligned}$$

- Use your results to the calculations above to calculate a value for I_A .
- Check these results against your measured values.

At a frequency of 1kHz

- Once again. notice how the share of the current changes. The reactance of the capacitor is 10 times *smaller* (i.e. 159.2Ω .) Thus, the capacitor offers a much easier path for the current and so passes a much *bigger* current.
- As usual, measure the AC supply voltage across the resistor and inductor again. The output impedance of the AC power supply itself will have an effect.
- Repeat the calculations at the new frequency, and check your results against the measured values.



For your records:

For a parallel combination of a resistor and capacitor, the total current I_S is given by:

$$I_S^2 = I_C^2 + I_R^2$$

where I_C = current through capacitor and I_R = current through resistor.

Using the AC version of Ohm's Law:

$$I_C = V_S / X_C \quad \text{and} \quad I_R = V_S / R$$

Worksheet 8

Parallel LCR circuit

ist2_1556878-rfid

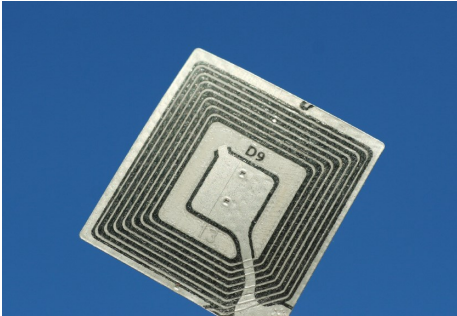

We return to the question of resonance again. In worksheet 5, you investigated a series circuit, which favoured one particular frequency, known as the resonant frequency, more than any other. Now you take a look at the behaviour of a parallel circuit.

Remember - inductors have a reactance that increases with frequency, capacitors have a reactance that decreases with frequency and resistors don't care about frequency.

Our parallel circuit has an inductor connected in parallel with a capacitor. In reality, the resistance of the wire used to make the inductor, appears in series with the inductor. To begin with, we assume that this is so small that we can ignore it. The procedure is the same as that used for the series circuit - measure current and voltage over a range of frequencies, and use these measurements to calculate the impedance of the circuit at that frequency.

Over to you:

Connect a 47mH inductor and a 1 μ F capacitor in parallel, as shown in the circuit diagram.

Set the AC power supply to output a frequency of **100Hz**.

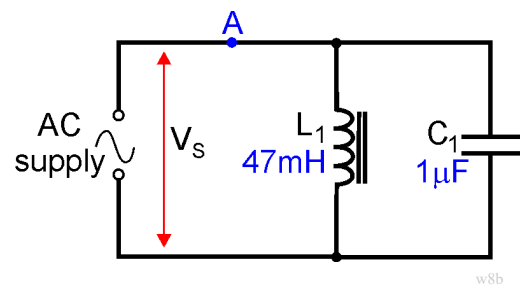

Remove the connecting link at **A**, and connect a multimeter, set to read up to 20mA AC, in its place. Record the current flowing at point **A** in the table. Remove the multimeter and replace the link.

Set up the multimeter to read AC voltages of up to 20V. Connect it to measure the AC supply voltage, V_s , applied across the two components, and record it in the table.

Change the frequency to 200Hz, and repeat the measurements. Again record them in the table.

Do the same for the other frequencies listed, and complete the table.

Frequency in Hz	AC supply voltage V_s in V	Current I at A in mA
100		
200		
300		
400		
500		
600		
700		
800		
900		
1000		

Worksheet 8

Parallel LCR circuit

So what?

- As before, the results will look clearer when we calculate the impedance of the circuit at the different frequencies.

- Complete the table, by calculating the impedance, Z , at each frequency, using the formula:

$$Z = V_S / I$$

- At low frequencies, the capacitor has a high reactance, and the inductor a low reactance, and so more current flows through the inductor than through the capacitor.

As the frequency rises, the capacitor's reactance falls, but the inductor's reactance increases. Gradually, the capacitor offers an easier path for the current than does the inductor. The resonant frequency is where the combined effect of the two, the circuit impedance,

is a **maximum**.

- Plot a graph of impedance against frequency, and use it to estimate the resonant frequency. A typical frequency response curve is shown opposite.

Frequency in Hz	AC supply voltage V_S in V	Current I at A in mA	Impedance Z in $k\Omega$
100			
200			
300			
400			
500			
600			
700			
800			
900			
1000			

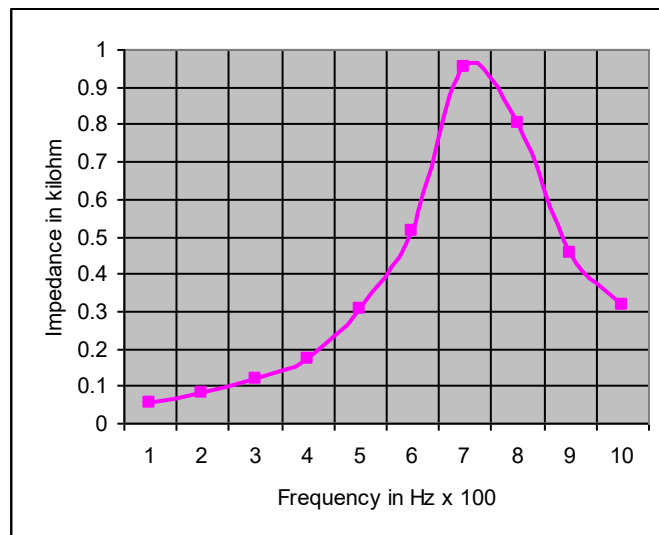

For your records:

For a parallel LCR circuit, the impedance is a maximum at the resonant frequency, f_R .

At frequencies below f_R , the inductor offers an easier route for the current. At frequencies above f_R , the capacitor offers an easier route.

Worksheet 9

Q Factor and Bandwidth



What connects trombones, bridges and wine glasses with LCR circuits? They all have a resonant frequency. In trombones, air vibrates at the resonant frequency, producing a musical note - usually desirable! Resonance can have undesirable effects too. Everyone has heard the story of the opera singer singing so loud that she shatters a wine glass. Bridges can also resonate. In November 1940, the bridge over Tacoma Narrows, near Seattle, USA, collapsed when the aerodynamic effects of the wind blowing over it made it vibrate at its resonant frequency. The replacement was made more rigid - given more resistance to vibration!

Well - LCR circuits behave in the same way when you add some resistance! It suppresses the vibration, making it less likely to build up.

Over to you:

Connect a 47mH inductor and a 1 μ F capacitor in series with the AC supply. This is the circuit you used in worksheet 5, though the procedure will be slightly different!

Set the AC supply to output a frequency of **100Hz**.

Connect a multimeter to measure the AC voltage, V_S , and record it in the table. Then measure, and record, the voltage, V_C across the capacitor.

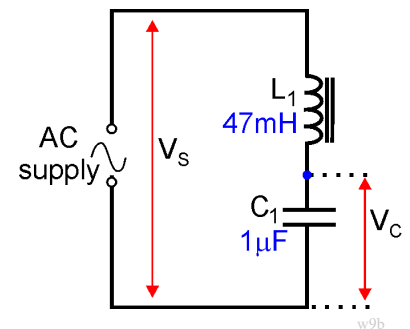

Change the frequency to 200Hz, repeat the measurements and record them.

Do the same for the other frequencies listed, and complete the table.

Next, connect a 10 Ω resistor in series with the inductor and capacitor, and repeat the measurements. Finally, swap the 10 Ω resistor for a 47 Ω resistor and repeat the measurements.

Frequency in Hz	No series resistor		10 Ω series resistor		47 Ω series resistor	
	V_S in V	V_C in V	V_S in V	V_C in V	V_S in V	V_C in V
100						
200						
300						
400						
500						
600						
700						
800						
900						
1000						

Worksheet 9

Q Factor and Bandwidth



So what?

- The 'Q' in Q factor stands for 'Quality'. There are several ways to view the Q factor of a resonant circuit.
 - The higher the quality, the longer it takes for the oscillations to die out.
 - The Q factor is a measure of the sharpness of the peak of the frequency response curve.
 - It is the ratio of energy stored, to the energy lost per cycle of the AC.
 - The higher the quality, the greater the voltage amplification of a resonant circuit.

- We will use this final version.

At resonance, the voltage across the inductor, V_L , is equal to the voltage across the capacitor, V_C .

The voltage amplification refers to the ratio of the voltage across the capacitor (or inductor, as it is equal,) to the supply voltage, V_S at resonance.

In other words: $Q \text{ factor} = V_C / V_S$

Frequency in Hz	0Ω	10Ω	47Ω
	V_C / V_S	V_C / V_S	V_C / V_S
100			
200			
300			
400			
500			
600			
700			
800			
900			
1000			

- Complete the table by calculating the ratio (V_C / V_S) for each frequency and for each value of series resistor used. The first row shows the value of the series resistor added to the resistance of the inductor, i.e. the resistance of the long length of wire used to wind the coil inside it.

- Plot three graphs to show the frequency responses of your three circuits,

(with no added resistance, with 10Ω added in series and with 47Ω added in series.)

The results should resemble those shown opposite.

- Use your 0Ω graph to estimate the Q factor of the L-C circuit.
- Notice the effect on the shape of the resonance curve, and on its Q factor of adding series resistance to the circuit.

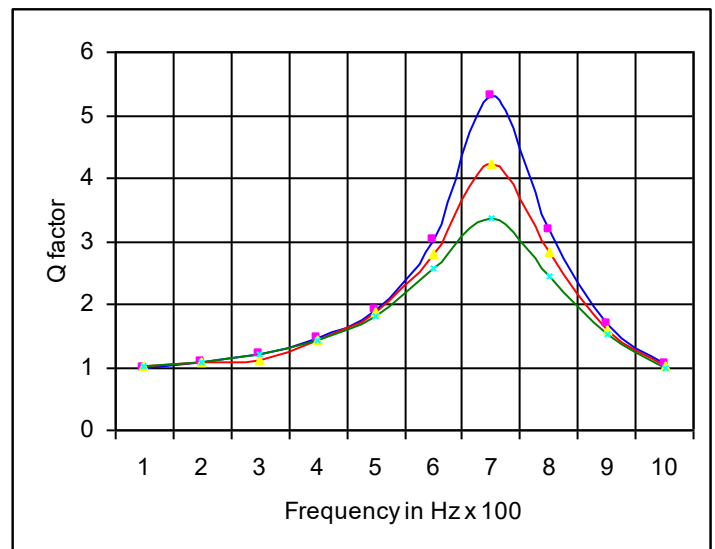

Worksheet 9

Q Factor and Bandwidth

So what?

- Another way to represent the sharpness of the frequency response peak is to calculate its bandwidth.

- The bandwidth of a signal is a measure of the range of frequencies present in it. Obviously, there must be a cut-off where we say that any weaker frequency components don't really count. This cut-off is usually taken to be the half-power points. On the diagram opposite these occur at the frequencies f_H and f_L . The bandwidth is calculated as $f_H - f_L$.

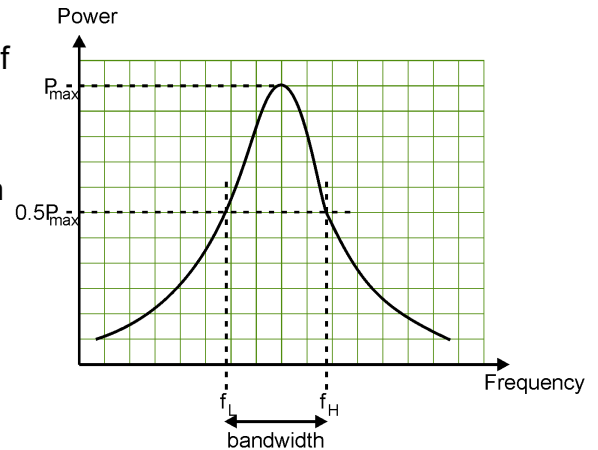

- The formula for electrical power, P , is:

$$P = I \times V$$

but this can be written as:

$$P = V^2 / R$$

In other words, the power dissipated depends on (voltage squared). To find the half-power points on a voltage / frequency graph, we have to look for the points where the voltage has dropped to 0.7 of its peak value (because 0.7^2 is roughly equal to 0.5, i.e. half-power)

- Estimate the bandwidth of the resonant frequency curve for each of your three graphs.



For your records:

At resonance, the voltage across the inductor, V_L , is equal to the voltage across the capacitor, V_C .

The higher the quality factor, the greater the voltage amplification of a resonant circuit.

Voltage amplification is the ratio of the voltage across the capacitor (or inductor, as it is equal,) to the supply voltage, V_S *at resonance*.

$$\text{In other words: } Q \text{ factor} = V_C / V_S$$

The bandwidth of a signal is a measure of the range of frequencies present in it. It is calculated as the range of frequencies between the half-power points, f_H and f_L or in other words, $\text{bandwidth} = f_H - f_L$. On a voltage / frequency graph, it is the range between the frequencies where the signal voltage has dropped to 0.7 (70%) of its peak value.

The effect of increasing the resistance in the resonant circuit is to reduce the Q factor, and increase the bandwidth of the resonance peak.

About this course

Introduction

The course is essentially a practical one. Locktronics equipment makes it simple and quick to construct and investigate electrical circuits. The end result can look exactly like the circuit diagram, thanks to the symbols printed on each component carrier.

Aim

The course introduces students to advanced concepts and relationships in electricity. It provides a series of practical experiments which allow students to unify theoretical work with practical skills in AC circuits.

Prior Knowledge

It is recommended that students have followed the 'Electricity Matters 1' and 'Electricity Matters 2' courses, or have equivalent knowledge and experience of building simple circuits, and using multimeters.

Learning Objectives

On successful completion of this course the student will:

- know that the opposition of an inductor to changing currents is called inductive reactance;
- be able to use the formula: $X_L = 2 \pi f L$ to calculate inductive reactance;
- be able to use the formula $X_L = V / I$, where V and I are rms voltage and current respectively.
- know that inductance is measured in a unit called the henry, (H) and that reactance is measured in ohms;
- know that the opposition of a capacitor to changing voltage is called capacitive reactance;
- be able to use the formula: $X_C = 1 / (2 \pi f C)$ to calculate capacitive reactance;
- be able to use the formula $X_C = V / I$, where V and I are rms voltage and current respectively;
- know that capacitance is measured in farads (F), or microfarads (μF);
- be able to calculate the impedance of a L-R circuit, using the formula: $Z = (R^2 + X_L^2)^{1/2}$;
- be able to calculate the (rms) current using: $I = V_S / Z$ where V_S = (rms) AC supply voltage;
- be able to calculate the voltage across a resistor using $V_R = I \times R$, across an inductor using $V_L = I \times X_L$ and across a capacitor using $V_C = I \times X_C$;
- be able to calculate the impedance of a C-R circuit using the formula: $Z = (R^2 + X_C^2)^{1/2}$
- know that the impedance is a minimum at the resonant frequency, in a series LCR circuit;
- be able to calculate resonant frequency in a series LCR circuit using the formula $f_R = 1 / 2 \pi \sqrt{L \times C}$
- know that inductors usually have some resistance as well, due to the long length of wire used in construction;
- know that the effect of this resistance is to dampen the resonance;
- be able to calculate the total current I_S using the formula: $I_S^2 = I_L^2 + I_R^2$ in a parallel L-R circuit;
- be able to use the formulae: $I_L = V_S / X_L$ and $I_R = V_S / R$ in a parallel L-R circuit;
- be able to calculate the total current I_S using the formula: $I_S^2 = I_C^2 + I_R^2$ in a parallel C-R circuit;
- be able to use the formulae: $I_C = V_S / X_C$ and $I_R = V_S / R$ in a parallel C-R circuit;
- know that impedance is a maximum at the resonant frequency in a parallel LCR circuit;
- be able to relate the quality factor to the voltage amplification in a resonant circuit;
- be able to calculate Q factor using the formula: Q factor = V_C / V_S ;
- know that the bandwidth of a signal is a measure of the range of frequencies present in it.
- be able to calculate the bandwidth of a resonance curve, using the half-power points;
- know the effect of increased resistance on the Q factor, and on the bandwidth in a resonant circuit .

What the student will need:

To complete the Advanced Electrical Principles DC and AC courses, the student will need the parts shown in the table.

In addition to this students will need a suitable signal generator like the LK8990.

Qty	Code	Description
1	HP4039	Lid for plastic trays
2	HP2666	International power supply with adaptors
1	HP5540	Deep tray
1	HP7750	Locktronics daughter tray foam insert
1	HP9564	62mm daughter tray
1	LK2871	Locktronics Warranty Document
1	LK4000	Locktronics User Guide
1	LK4025	Resistor - 10 ohm, 1W 5% (DIN)
1	LK4065	Resistor - 47R. 1/4W 5% (DIN)
1	LK5100	Locktronics current probe
1	LK5202	Resistor - 1K, 1/4W, 5% (DIN)
3	LK5203	Resistor - 10K, 1/4W, 5% (DIN)
1	LK5205	Resistor - 270 ohm 1/4W, 5% (DIN)
1	LK5209	Resistor - 5.6K, 1/4W, 5% (DIN)
12	LK5250	Connecting Link
1	LK6201	Resistor - 330K, 1/4W, 5% (DIN)
2	LK6205	Capacitor, 1 uF, Polyester
1	LK6211	Resistor - 22K, 1/4W, 5% (DIN)
1	LK6213	Resistor - 15K 1/4W, 5% (DIN)
1	LK6214R2	Choke 47mH
1	LK6218	Resistor - 2.2K, 1/4W, 5% (DIN)
1	LK6492	Curriculum pack CD ROM
1	LK6917	Locktronics blister pack lid
1	LK6921	Locktronics blister pack clear tray & insert
2	LK7461	Power supply carrier with voltage source symbol
1	LK8022	General puprpose lead set (LK5603 x 2, LK5604 x 2)
1	LK8900	7 x 5 baseboard with 4mm pillars

Power source:

Although there are two ways to power these circuits, either with C type batteries on a baseboard containing three battery holders, or using a mains-powered power supply, at this level the latter is more suitable, and the worksheets are written using that approach.

The larger baseboard is appropriate for use with this power supply., which can be adjusted to output voltages of either 3V, 4.5V, 6V, 7.5V, 9V or 12V, with currents typically up to 1A. The voltage is changed by turning the selector dial just above the earth pin until the arrow points to the required voltage. The instructor may decide to make any adjustment necessary to the power supply voltage, or may allow students to make those changes.

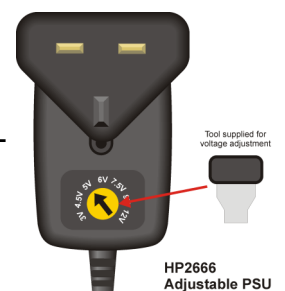

Using this course:

It is expected that the series of experiments given in this course is integrated with teaching or small group tutorials which introduce the theory behind the practical work, and reinforce it with written examples, assignments and calculations.

The worksheets should be printed / photocopied / laminated, preferably in colour, for the students' use. Students should be encouraged to make their own notes, and copy the results tables, working and sections marked 'For your records' for themselves. They are unlikely to need their own permanent copy of each worksheet.

Each worksheet has:

- an introduction to the topic under investigation;
- step-by-step instructions for the investigation that follows;
- a section headed 'So What', which aims to collate and summarise the results, and offer some extension work. It aims to encourage development of ideas, through collaboration with partners and with the instructor.
- a section headed 'For your records', which can be copied and completed in students' exercise books.

This format encourages self-study, with students working at a rate that suits their ability. It is for the instructor to monitor that students' understanding is keeping pace with their progress through the worksheets. One way to do this is to 'sign off' each worksheet, as a student completes it, and in the process have a brief chat with the student to assess grasp of the ideas involved in the exercises it contains.

Time:

It will take students between seven and nine hours to complete the worksheets.

It is expected that a similar length of time will be needed to support the learning that takes place as a result.

Using multimeters to measure AC quantities:

Instructors should be aware that multimeters have limitations when used to measure AC quantities. Their accuracy will decrease when used at high frequencies, because of the effect of their input impedance. The data sheet for the multimeter will give details about this. The frequencies used in this course are unlikely to cause problems to most multimeters.

Instructors may prefer that students use oscilloscopes to make AC voltage measurements on the circuits. In this way, the range of frequencies used in the investigations could be extended. This could be set as a challenge for more able students.

Worksheet	Notes for the Instructor	Timing
1	<p>The aim of the investigation is introduce the student to the effects of inductive reactance.</p> <p>As students may be unfamiliar with using the AC power supply, the instructor should check that it is set to the correct frequency of 50Hz.</p> <p>For those returning to electrical studies after a break, it is an opportunity to revisit the skills involved in using multimeters to measure current and voltage. In particular, students should be reminded that voltage measurements can be made without interrupting the circuit, as the multimeter is then connected in parallel with the resistor under investigation. On the other hand, to measure current at a point in the circuit, the circuit must be broken at that point and the multimeter inserted there to complete the circuit.</p> <p>Instructors need to be aware that the low current ranges on most multimeters are protected by internal fuses. If a student is having difficulty in getting readings from a circuit, it may be that this internal fuse has blown. It is worth having some spare multimeters available, and the means to change those fuses, to streamline the lesson.</p> <p>A comparison is made between resistors, which oppose current, and inductors, which oppose changing current. The instructor might wish to elaborate on this, and expand on what is meant by 'rate of change of current'.</p> <p>Students often find it confusing that reactance is measured in ohms. The point should be made that this comes from the definition of inductive reactance and a formula that looks like, but has nothing to do with, Ohm's law. The opposition caused by resistors is the resistance. However, the opposition caused by inductors is not the inductance, but the inductive reactance.</p> <p>They will need plenty of practice in calculating this from the formula: $X_L = 2 \pi f L$ as they confuse the terms f and L, and find it difficult to convert multipliers such as 'milli' often used with inductance.</p>	30 - 45 mins
2	<p>This is the introductory worksheet for capacitors, equivalent to Worksheet 1.</p> <p>It is important that students appreciate that inductors and capacitors are really mirror-images of each other. The former sets up a magnetic field, the latter an electric field. The former has a slowly increasing current, once a voltage is applied to it. The latter has a slowly increasing voltage across it, as a current flows in the circuit. Inductors oppose a changing current, capacitors a changing voltage. This opposition increases with frequency in inductors, but decreases with frequency in capacitors.</p> <p>The treatment given in the worksheet makes no mention of phasor diagrams, but the instructor may wish to introduce these to support the student's understanding.</p> <p>As pointed out above, there is widespread confusion among students over the difference between reactance and, in this case, capacitance. The opposition caused by resistors is the resistance. However, the opposition caused by capacitors is not their capacitance, but their capacitive reactance.</p> <p>They will need plenty of practice in calculating this from the formula: $X_C = 1 / 2 \pi f C$ as they find it difficult to convert multipliers such as 'micro' and 'nano'.</p>	30 - 45 mins

Worksheet	Notes for the Instructor	Timing
3	<p>A series combination of inductor and resistor acts as a frequency-dependent voltage divider. In effect it separates the range of frequencies into two. Low frequencies set up big voltages across the resistor, high frequencies across the inductor. This kind of circuit is often referred to as a filter for that reason.</p> <p>The treatment offered here hints at the issues over phase shift, but does not go into detail. The instructor must judge whether a particular class needs, and can cope with, a more detailed account, perhaps including phasor diagrams.</p> <p>Similarly, the concept of impedance is introduced without explanation, and the formula for impedance in a series circuit is thrown in without any supporting theory.</p> <p>Students then use their measured value of the supply AC voltage to calculate the current flowing, and from that the voltage across the resistor and across the inductor, so that these can be compared with the measured values.</p> <p>They then repeat the whole process for a supply frequency of 10kHz. The reactance of the inductor is now ten times greater than before, so that it dominates the voltage divider at this frequency, demonstrating the filter effect mentioned above.</p>	25 - 40 mins
4	<p>This is a parallel investigation to the one in the previous worksheet but for capacitor - resistor networks. The same ideas apply. The reactance of the capacitor and the resistance of the resistor cannot be combined in a simple additive manner because of the phase shifts involved. Again, the instructor might decide to go into this in more detail with a more able class.</p> <p>The approach is identical to that in Worksheet 3, except that the second frequency chosen is ten times smaller, i.e. 100Hz. The students should be encouraged to notice the similarities and differences between the two situations. Here, once again, the reactance is ten times bigger at the second frequency, and so this time the capacitor dominates the voltage divider at this second frequency. In other words, low frequencies set up large voltages across the capacitor, whereas high frequencies do so across the resistor.</p>	25 - 40 mins
5	<p>Having studied inductors and capacitors separately previously, this worksheet now combines them, and introduces the concept of resonance in the process.</p> <p>Instructors should mention that resonance is a widespread effect seen in any oscillating system. In some, such as musical instruments, it is advantageous, and students might be asked to research how the resonant frequency can be changed in, say, wind and string instruments, so that different notes are produced. In some systems, particularly in civil and mechanical engineering, resonance can cause real problems, from annoying rattles that occur in cars at particular speeds, to vibrations in aircraft wings and bridges that threaten complete mechanical failure.</p> <p>continued on next page...</p>	

Worksheet	Notes for the Instructor	Timing
5	<p>... continued from previous page</p> <p>Electrical resonance has a number of applications. The obvious one is the tuned circuit in a radio, where the very weak electrical signals picked up by the aerial stimulate the tuned circuit to oscillate at its resonant frequency. Other uses include an implant which is heated by stimulating it at its resonant frequency by high frequency radio waves, to kill cancerous cells located nearby, and the increasingly important techniques of RFID (radio frequency identification,) where passive (unpowered) devices can pick up enough energy, because of being stimulated at their resonant frequency, to transmit information to a nearby device.</p> <p>The approach here is to look at what happens to the impedance of the circuit as the applied frequency is changed. In other words, the circuit offers less hindrance to some frequencies and more to others. Although there is no added series resistor, students should be made aware that the windings of the inductor coil have resistance. The effect of this will be explored in worksheet 9.</p> <p>At resonance, the voltage across the capacitor is equal and opposite to that across the inductor, and so the two cancel each other out. The only hindrance to the flow of current is then the resistance of the various elements in the circuit, particularly the inductor. Equally, because the voltages across the capacitor and inductor cancel each other out, there is no reason why these cannot be very large voltages. Again, this voltage amplification effect is explored later.</p> <p>These large-scale effects occur in other examples of resonance, such as the much-publicised shattering of a wine glass by the singing voice of an opera singer.</p>	25 - 40 mins
6	<p>Whereas series combinations of inductors, resistors and capacitors make frequency-dependent voltage dividers, parallel combinations form frequency-dependent current dividers.</p> <p>This worksheet introduces the first of these, the parallel L-R circuit.</p> <p>The treatment deliberately avoids the issue of impedance in parallel circuits, because the relevant formula is quite complicated. Instead, it looks at the currents in various parts of the circuit, and how they are related. There are phase shift issues again, and the formula that is dropped in to calculate total current comes directly from the phasor diagram for this circuit, though this is not explained. In this case, the voltage across the components is the same. The current through the resistor is in phase with it, but the current in the inductor lags behind by 90°. The instructor must judge how much of this needs to be explained to the class.</p> <p>As before, students use their measured value of the supply voltage to calculate the currents flowing through the inductor and resistor, and then combine these to calculate a value for the total current flowing.</p> <p>The investigation is repeated for a second, higher, frequency to show that the distribution of current is frequency dependent.</p>	30 - 45 mins

Worksheet	Notes for the Instructor	Timing
7	<p>This is the equivalent investigation for parallel C-R circuits.</p> <p>The approach is identical, and again the formula for impedance is studiously avoided, because of its complexity. Students should know that the formula used for impedance in earlier worksheets applied only to series combinations, but the investigations in this and the previous worksheet avoid the need to calculate impedance itself.</p> <p>The measurements are repeated for a frequency of 10kHz, to show that this changes the pattern of currents. Now the capacitor has a much lower reactance, and so passes a higher current.</p> <p>Students should be helped to visualise that here we are using a relatively pure single frequency, whereas in many systems, the signal is a combination of many frequencies, and then the way the currents divide differs depending on frequency.</p>	30 - 45 mins
8	<p>Students should compare the behaviour of this circuit, a parallel LCR circuit, with that of the series LCR circuit studied in Worksheet 5.</p> <p>Students measure the AC supply voltage and the total current leaving the power supply, and from that calculate the circuit impedance. The emergence of a resonant frequency becomes apparent when the impedance calculations are carried out. This time, though, the circuit impedance is a maximum at the resonant frequency, not a minimum.</p> <p>The behaviour of inductive and capacitive reactances above and below the resonant frequency are described, but this may need reinforcing in class discussion.</p>	30 - 45 mins
9	<p>Students have now investigated two forms of electrical resonance, one in series LCR circuits, and one in parallel LCR circuits.</p> <p>The next concept introduced is that of Q factor, essentially how sharp the resonance curve is. The controlling influence here is the total resistance of the circuit. The greater it is, the less the circuit notices the resonant frequency. For mechanical systems such as bridges, this is the ideal behaviour - despite stimulation at the resonant frequency, the vibrations of the structure are very small.</p> <p>There are several ways to calculate the Q factor for a vibrating system. The one used here essentially looks at the ratio of energy stored to energy lost per cycle, though this boils down to the ratio of peak voltage across the capacitor (or inductor, as these are equal at resonance,) to the supply voltage.</p> <p>The investigation then looks at the effect on the resonance curve of adding extra series resistors.</p> <p>Then the concept of bandwidth is introduced. It is defined in terms of the half-power points on the frequency spectrum for the signal. In reality, this is not often a useful way to measure bandwidth, as usually voltage, not power is measured. Therefore, bandwidth is then defined in terms of voltages. To find the point at which the power has dropped to 0.5, we look for the points at which the voltage has dropped to 0.7 of its peak, since power depends on (voltage)², and $(0.7)^2 = 0.5$, roughly!</p>	30 - 45 mins