



Simplifying Electricity

Advanced electrical principles – DC



CP8473

MATRIX
www.matrixmultimedia.com

Copyright © 2009 Matrix Multimedia Limited

Worksheet 1 - Resistors in Series	3
Worksheet 2 - Resistors in Parallel	5
Worksheet 3 - Series / Parallel Circuit	7
Worksheet 4 - Voltage Divider Circuits	9
Worksheet 5 - Current Divider Circuits	11
Worksheet 6 - Using Kirchhoff's Laws	13
Worksheet 7 - Using Superposition	15
Worksheet 8 - Using Thevenin's Theorem	17
Worksheet 9 - Maximum Power Transfer	19
Instructor Guide	21

Worksheet 1

Resistors in Series



Resistors are basic components in electrical and electronic systems.

A series connection is one of the simplest ways to join them. In a series connection, there are no alternative

routes and no junctions for the current.

Over to you:

Connect a 270Ω resistor, a 1kΩ resistor and a 2.2kΩ resistor in series with the power supply, as shown in the circuit diagram.

Use extra connecting links so that the current can be measured at points A, B, C and D.

The photograph shows one way to build the circuit.

Set the power supply to give a 4.5V output.

Remove the connecting link at A, and connect a multimeter, set to read up to 2mA DC, in its place. Record the current flowing at point A in the table.

Remove the multimeter and replace link A.

Remove the connecting link at B, and use a multimeter to measure the current here. Record the current flowing at point B, in the table.

In the same way, measure the current at points C and D and record them.

Set up the multimeter to read DC voltages of about 5V and connect it in parallel with resistor R₁, as shown. Record the voltage in the table.

In the same way, measure and record the voltages across R₂ and R₃.

Now change the power supply voltage to 9V and repeat the whole process with the new supply voltage.

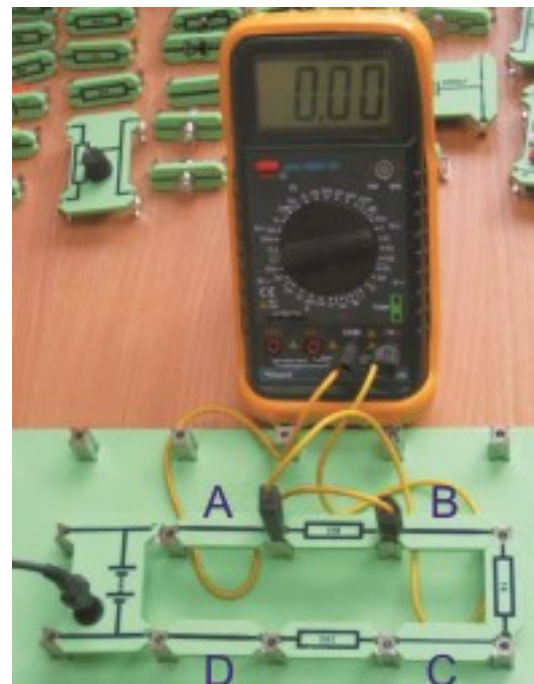
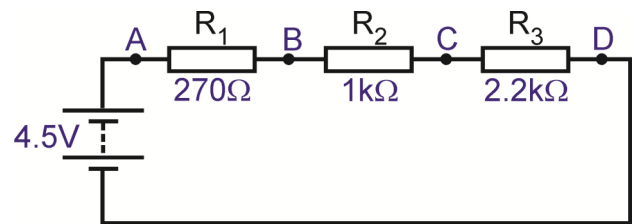

Power supply voltage	4.5V	9V
Current at point A in mA		
Current at point B in mA		
Current at point C in mA		
Current at point D in mA		
Voltage across R ₁ (270Ω resistor)		
Voltage across R ₂ (1kΩ resistor)		
Voltage across R ₃ (2.2kΩ resistor)		

Worksheet 1

Resistors in Series

So what?

- You probably noticed that the current readings at **A**, **B**, **C** and **D** are virtually identical. They should be, as there is only one route for the current to flow down.
- Use your four current readings to obtain an average value for the current. Write down this value, as I , in the next table.

Power supply voltage	4.5V	9V
Average current I in mA		
Total voltage V_S across all resistors		
Total resistance $R_T = V_S / I$		
Total resistance $R_T = R_1 + R_2 + R_3$		

- Add together the voltages across the three resistors and write that in the table. You should have found that this total voltage, V_S , is equal to the supply voltage.
- There are two ways to calculate the total resistance, R_T , of the resistors:
 - * We can use I and V_S in the formula $R = V/I$, from Ohm's Law. Calculate the total resistance in this way, and enter the result in the table.
 - * The total resistance of three resistors connected in series is equal to the sum of their resistance. Calculate the total resistance in this way, and write the result in the table.
- Compare the two values for the total resistance. Think of reasons why these might be different.



For your records:

- In a series circuit, the power supply voltage is shared between all the components connected in series.
- As a result, in this case, when you add together the voltages across the three resistors, the total is equal to the power supply voltage.
- In a series circuit, there is only one pathway for the electrons to flow from one terminal of the power supply to the other.
- As a result, the same current flows in all parts.
- The effective resistance of three resistors connected in series is the sum of their individual resistances: $R_T = R_1 + R_2 + R_3$

Worksheet 2

Resistors in Parallel

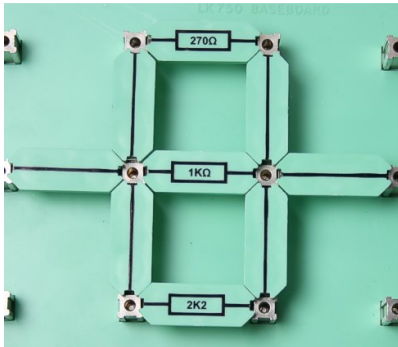

w2a

When resistors are connected in parallel, they offer different routes for the electric current. An easier route will pass a greater current.

The same effect is seen with traffic. When a bypass (parallel connection) opens, more vehicles pass along it than struggle to go along the original route.

Combining resistors in parallel reduces the total resistance of a circuit, allowing more

Over to you:

Connect a 270Ω resistor, a $1k\Omega$ resistor and a $2.2k\Omega$ resistor in parallel, as shown in the circuit diagram.

Use extra connecting links so that the current can be measured at points A, B, C and D.

The photograph shows one way to do this.

Set the power supply to give a 4.5V output.

Remove the connecting link at A, and connect a multimeter, set to read up to 2mA DC, in its place. The photograph shows the multimeter in position to do this. Record the current flowing at point A in the table.

Remove the multimeter and replace link A.

Remove the connecting link at B, and use a multimeter to measure the current here. Record the current flowing at point B, in the table.

In the same way, measure the current at points C, D and E and record them.

Set up the multimeter to read DC voltages of about 5V and connect it in parallel with resistor R_1 , as shown. Record the voltage in the table.

Then set the multimeter up to read the voltages across R_2 and R_3 , and record them in the table.

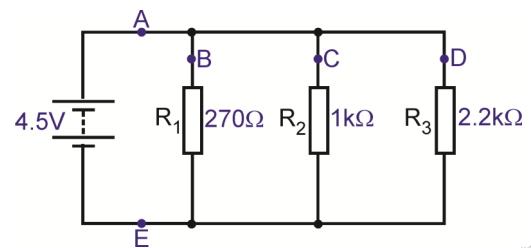

w2b

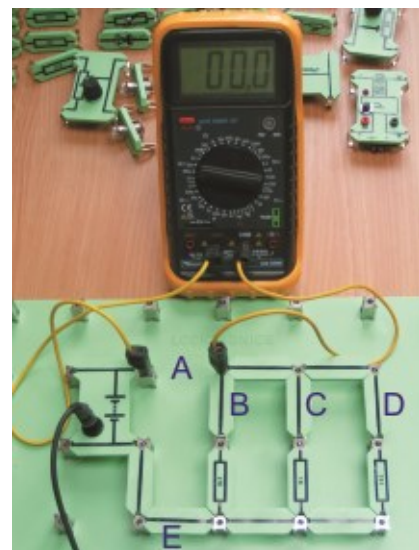

w2c

Power supply voltage	4.5V
Current at point A in mA	
Current at point B in mA	
Current at point C in mA	
Current at point D in mA	
Current at point E in mA	
Voltage across R_1 (270Ω resistor)	
Voltage across R_2 ($1k\Omega$ resistor)	
Voltage across R_3 ($2.2k\Omega$ resistor)	

Worksheet 2

Resistors in Parallel

So what?

- The current readings at **B**, **C** and **D** are different, as there are three different routes the current can take. The current through R_1 , the smallest resistor, should be the biggest as it offers the easiest route. As R_1 is about four times smaller than R_2 , the current at **B** should be about four times bigger than the current at **C**. Similarly, the current at **C** should be about twice as big as the current at **D**.
- The current from the power supply divides up between the three possible routes, and then joins back up again. So, when you add together the currents at **B**, **C** and **D**, the total should equal the current at **A**. The current at **A** should be virtually the same as the current at **E**. Complete rows 1, 2 and 3 of the following table.

Power supply voltage	4.5V
Average of currents at A and E in mA	
Total of currents, I, at B, C and D in mA	
Average voltage across resistors V_S	
Total resistance $R_T = V_S / I$	
Total resistance from $1/R_T = 1/R_1 + 1/R_2 + 1/R_3$	

- The voltage readings across the three resistors should be virtually the same, and should equal the power supply voltage. Enter the average of these readings, V_S , in the table.
- Calculate the total resistance R_T of the three resistors, in two ways, as before:
 - * Use I and V_S in the formula $R = V/I$, from Ohm's Law and enter the result in the table.
 - * Use the formula $1/R_T = 1/R_1 + 1/R_2 + 1/R_3$, and write the result in the table.
- Compare these two values for total resistance. Again, why might these be different?



For your records:

- In a parallel circuit, the current is shared between all components connected in parallel.
- In a parallel circuit, each component is connected directly to the two terminals of the power supply and so has the full supply voltage across it.
- The total resistance, R_T of three resistors in parallel is:

$$1/R_T = 1/R_1 + 1/R_2 + 1/R_3$$

- For two resistors in parallel, this reduces to:

$$R_T = \frac{R_1 \times R_2}{R_1 + R_2}$$

For the circuit shown opposite, calculate:

- total resistance;
- current I ;
- current through resistor R_1 .

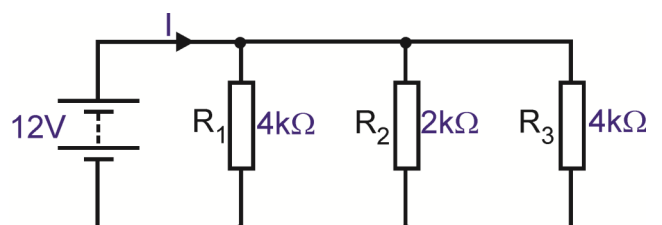

Worksheet 3

Series / Parallel Circuit

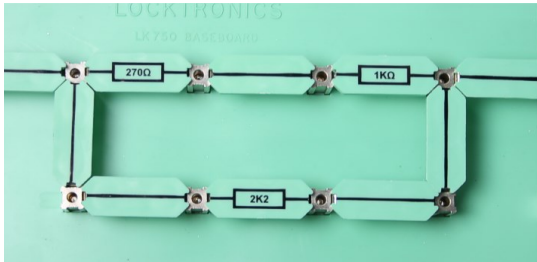

In most electrical circuits, some components are connected in series, while others are in parallel. The rules developed in the previous worksheets still apply, but only to the appropriate parts, instead of the whole circuit.

In a complex circuit, components in parallel have the same voltage across them but may carry different currents, while components in series have the same current flowing through them but may have different voltages across them.

Over to you:

Connect a 270Ω resistor, a $1k\Omega$ resistor and a $2.2k\Omega$ resistor, as shown in the circuit diagram. The 270Ω and $1k\Omega$ resistor are in series, while the $2.2k\Omega$ resistor is in parallel with the combination.

Use extra connecting links so that the current can be measured at points A, B, C and D.

The photograph shows one way to do this.

Set the power supply to give a 4.5V output.

Remove the connecting link at A, and connect a multimeter to read the current at A. Record the measurement in the table.

Remove the multimeter and replace link A.

Remove the connecting link at B, and use a multimeter to measure the current here. Record the current flowing at point B, in the table.

In the same way, measure the current at points C, and D and record them.

Set up the multimeter to read the voltage across resistor R_1 . Record the voltage in the table.

Then connect the multimeter up to read the voltage across R_2 and R_3 , in turn, and record them in the table.

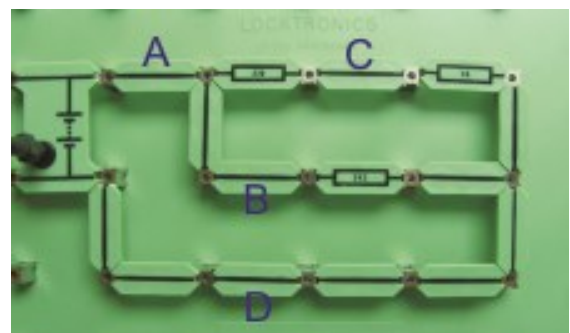
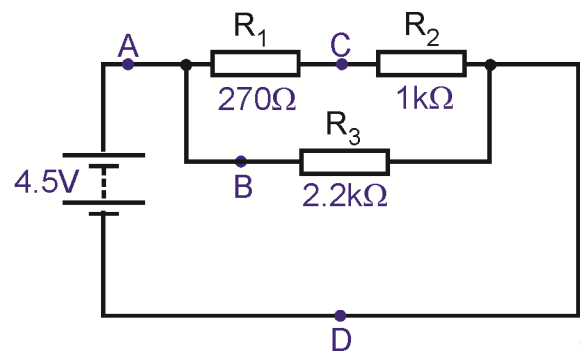

Power supply voltage	4.5V
Current at point A in mA	
Current at point B in mA	
Current at point C in mA	
Current at point D in mA	
Voltage across R_1 (270Ω resistor)	
Voltage across R_2 ($1k\Omega$ resistor)	
Voltage across R_3 ($2.2k\Omega$ resistor)	

Worksheet 3

Series / Parallel Circuit

So what?

- The same current flows through R_1 and R_2 , as they are in series. This is the current you measured at point **C**.
- The current readings at **A** and **D** should be the same, as these measure the total current leaving and returning to the power supply.
- The current from the power supply splits, with part going through R_1 (and then R_2), while the rest flows through R_3 . In other words, adding together the readings at **B** and **C** should give a total equal to the reading at **A** (and **D**).
- The full power supply voltage appears across R_3 , but is split between R_1 and R_2 . Complete rows 1, 2 and 3 of the following table.

Power supply voltage	4.5V
Average of currents at A and D in mA (= I)	
Sum of currents at B and C in mA	
Sum of voltages across R_1 and R_2 (= V_S)	
Total resistance $R_T = V_S / I$	
Combined resistance of R_1 and R_2 (in series) (= R_C)	
Total resistance of all three resistors $R_T = R_C \times R_3 / R_C + R_3$	

- Complete the table by calculating the total resistance R_T of the three resistors by:
 - * using I and V_S in the formula $R = V/I$;
 - * adding together the resistance of R_1 and R_2 , as these are in series, to give R_C , their combined resistance, and then using $R_T = R_C \times R_3 / R_C + R_3$.
- Think of reasons why these two approaches might give different values for R_T . Which, do you think, gives the more reliable result?



For your records:

For the circuit shown opposite, calculate:

- total resistance;
- current at **P**;
- voltage across R_3 , the $6k\Omega$ resistor;
- current at **R**;
- current at **Q**;
- voltage across R_1 , the $8k\Omega$ resistor.

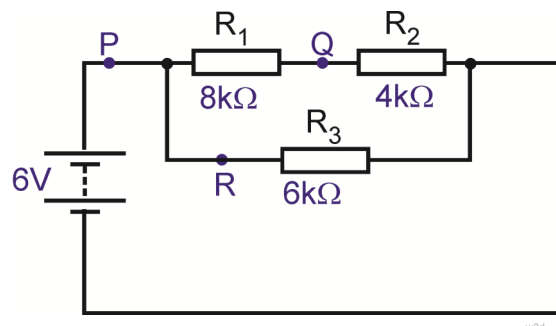

Worksheet 4

Voltage Divider Circuits

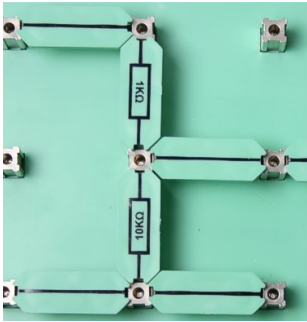

Resistors can be used to protect other components from excessive current.

They can also be used in voltage dividers to carve up a voltage, from the power supply, for example, into smaller, predictable portions. This is particularly useful when one of the resistors is a sensing component, such as a LDR (light-dependent resistor,) or a thermistor, (temperature-dependent resistor.)

Voltage dividers form the basis of many sensing sub-systems. The output voltage can represent temperature, light-level, pressure, humidity, strain or other physical quantities.

Over to you:

Connect two 10kΩ resistors in series, as shown in the circuit diagram.

Set the power supply to give a 6V output.

Remove the connecting link at **A**. Connect a multimeter, set on the 2mA DC range, to measure the current. Record the value in the table.

Remove the multimeter and replace link **A**.

Set up the multimeter to read DC voltages of about 5V, and connect it to read first, the voltage across resistor R_1 , and then across R_2 . Record the voltages in second column of the table.

Next, set the power supply to 9V, and repeat the measurements. Record them in the third column of the table.

Now, swap resistor R_1 for a 1kΩ resistor. Repeat the process and record the results in the second table.

Finally, replace both resistors, with a 2.2kΩ resistor for R_1 , and a 22kΩ resistor for R_2 . Repeat the measurements and record them in the third table.

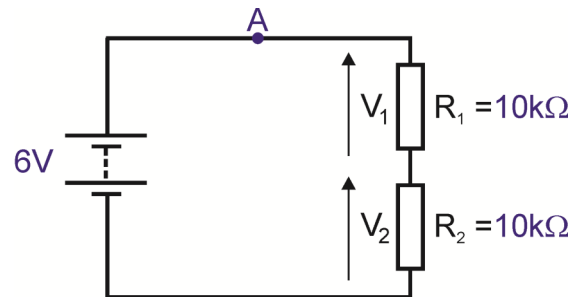

$R_1 = 10k\Omega, R_2 = 10k\Omega$		
Power supply voltage	6V	9V
Current at point A in mA		
Voltage V_1 across R_1		
Voltage V_2 across R_2		

$R_1 = 1k\Omega, R_2 = 10k\Omega$	
Power supply voltage	9V
Current at point A in mA	
Voltage V_1 across R_1	
Voltage V_2 across R_2	

$R_1 = 2.2k\Omega, R_2 = 22k\Omega$	
Power supply voltage	9V
Current at point A in mA	
Voltage V_1 across R_1	
Voltage V_2 across R_2	

Worksheet 4

Voltage Divider Circuits

So what?

First of all, look at the theoretical behaviour of this circuit -

- Resistors R_1 and R_2 are connected in series. Their total resistance, is given by:

$$R_T = (R_1 + R_2).$$

- The full power supply voltage, V_S , appears across this total resistance, R_T , and so the current I , flowing through the two resistors is given by:

$$I = V_S / R_T$$

- The voltage across resistor R_1 is given by:

$$V_1 = I \times R_1$$

- The voltage across resistor R_2 is given by:

$$V_2 = I \times R_2$$

- Calculate R_T , I , R_1 and R_2 for each of the circuits looked at, and complete the next table with your results:

Circuit	R_T	I	V_1	V_2
$R_1 = 10k\Omega$, $R_2 = 10k\Omega$, $V_S = 6V$				
$R_1 = 10k\Omega$, $R_2 = 10k\Omega$, $V_S = 9V$				
$R_1 = 1k\Omega$, $R_2 = 10k\Omega$, $V_S = 9V$				
$R_1 = 2.2k\Omega$, $R_2 = 22k\Omega$, $V_S = 9V$				

- Compare the values of V_1 and V_2 with those you measured for each circuit. Why might you expect the experimental values to be different?



For your records:

There is a straightforward way to view these results:

- The voltage from the power supply is shared between the resistors, so that $V_1 + V_2 = V_S$.
- The bigger the resistor, the bigger its share of the voltage.

In the first circuit, $R_1 = R_2 = 10k\Omega$ so $V_1 = V_2 = \frac{1}{2}V_S$.

In the second and third circuits, $R_2 = 10 \times R_1$, and so $V_2 = 10 \times V_1$.

The second and third circuits seem to perform in the same way, except for current. In some cases, it is best to use big resistor values, to reduce battery drain and power dissipation.

However, using lower resistor values allows us to draw current from the voltage divider circuit without really affecting voltage V_1 and V_2 .

Worksheet 5

Current Divider Circuits

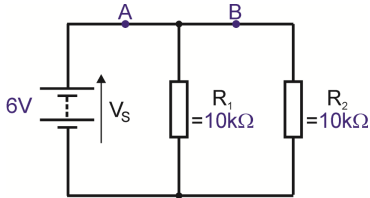

w5a

Voltage dividers use resistors connected in **series** to divide up a voltage into calculable fractions.

Current dividers use resistors connected in **parallel** to set up known fractions of current.

Current dividers are used in ammeters. A known fraction of the total current passes through the meter and is measured. From that the total current is calculated .

Over to you:

Connect two 10kΩ resistors in parallel, as shown in the circuit diagram.

Set the power supply to give a 6V output.

Remove the connecting link at **A**. Connect a multimeter, set on the 2mA DC range, to measure the current, I_1 , at A (the total current leaving the power supply.) Record the value in the table.

Remove the multimeter and replace link **A**.

Measure the current at **B**, I_2 , in the same way, and record the result in the table.

Set up the multimeter to read DC voltages of about 10V, and connect it across the power supply to read V_s . Record it in the table.

Next, set the power supply to 9V, and repeat the measurements. Record them in the second table.

Lastly, swap resistor R_1 for a 1kΩ resistor.

Change the multimeter range to 10mA

Repeat the process, with the multimeter set to the 10mA range when measuring currents.

Record the results in the third table.

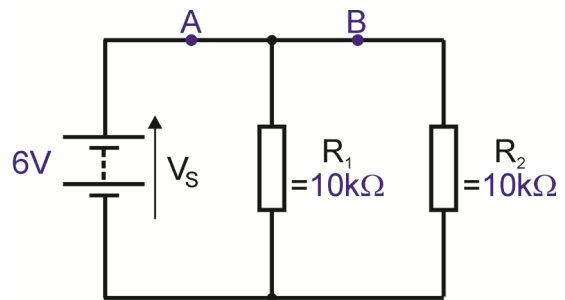

w5b

$R_1 = 10k\Omega$, $R_2 = 10k\Omega$
Power supply set to 6V

Power supply voltage, V_s	
Current at point A, I_1 , in mA	
Current at point B, I_2 , in mA	

$R_1 = 10k\Omega$, $R_2 = 10k\Omega$
Power supply set to 9V

Power supply voltage, V_s	
Current at point A, I_1 , in mA	
Current at point B, I_2 , in mA	

$R_1 = 1k\Omega$, $R_2 = 10k\Omega$
Power supply set to 9V

Power supply voltage, V_s	
Current at point A, I_1 , in mA	
Current at point B, I_2 , in mA	

Worksheet 5

Current Divider Circuits

So what?

First of all, the theoretical behaviour -

- The voltage across resistor $R_1 = V_S$, and so:

$$V_S = I_1 \times R_1$$

- Similarly, $V_S = I_2 \times R_2$
which means that: $I_1 \times R_1 = I_2 \times R_2$

or: $I_1 = I_2 \times (R_2 / R_1)$

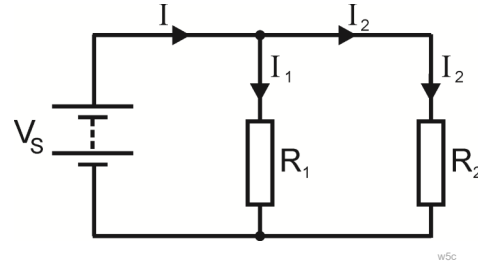

The current I from the power supply splits into I_1 and I_2 at the junction.

In other words:

$$I = I_1 + I_2$$

Using the equation for I_1 given above: $I = I_2 \times (R_2 / R_1) + I_2$

$$= I_2 (1 + R_2 / R_1)$$

Re-arranging this gives

$$I_2 = I \times \left(\frac{R_1}{R_1 + R_2} \right)$$

This can be used to calculate the current I_2 flowing in the branch of the circuit.

- Use this formula to calculate I_2 in the three cases you looked at in your investigation. Write your results in the following table:

Circuit	I_2 in mA
$R_1 = 10\text{k}\Omega$, $R_2 = 10\text{k}\Omega$ Power supply set to 6V	
$R_1 = 10\text{k}\Omega$, $R_2 = 10\text{k}\Omega$ Power supply set to 9V	
$R_1 = 1\text{k}\Omega$, $R_2 = 10\text{k}\Omega$ Power supply set to 9V	

- Compare the calculated values of I_2 with those you measured for each circuit. Once again, why might you expect the experimental values to be different?



For your records:

As with voltage dividers, there is a straightforward way to view these results:

- The current from the power supply is shared between the resistors, so that $I = I_1 + I_2$
- The *bigger* the resistor, the *smaller* its share of the current.

In the first and second circuits, $R_1 = R_2 = 10\text{k}\Omega$ so $I_1 = I_2 = \frac{1}{2} I$.

In the third circuit, $R_2 = 10 \times R_1$, and so $I_1 = 10 \times I_2$.

Worksheet 6

Using Kirchhoff's Laws

- **Kirchhoff's Current Law** - 'What flows in must flow out'
The (vector) sum of all currents at any junction is zero.
In other words, $I_1 = I_2 + I_3$

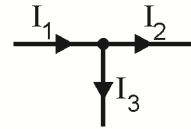

w6c

- **Kirchhoff's Voltage Law** -
Around any loop in the circuit, the (vector) sum of voltages is zero.

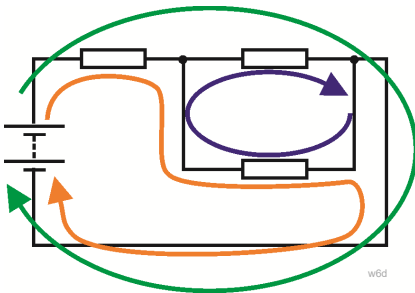

w6d

There are three loops in the circuit you will investigate. These are shown in different colours in the diagram.

Over to you:

Connect a 1kΩ, a 2.2kΩ and a 10kΩ resistor, as shown in the circuit diagram.

Set the power supply to give a 9V output.

Remove the connecting link at **P**. Connect a multimeter, set on the 10mA DC range, to measure the current at **P**, (the total current leaving the power supply.) Record the value in the table.

Remove the multimeter and replace link **P**.

Measure the current at **Q** and then **R** in the same way, and record the results in the table.

Set up the multimeter to read DC voltages of about 10V, and use it to measure the voltages across the three resistors.

Record them in the table.

Next, we are going to analyse these results using Kirchhoff's Current and Voltage Laws.

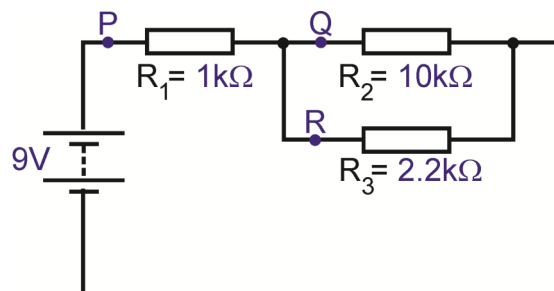

w6a

Measurement	Value
Current at point P in mA	
Current at point Q in mA	
Current at point R in mA	
Voltage across R ₁	
Voltage across R ₂	
Voltage across R ₃	

Worksheet 6

Using Kirchhoff's Laws

So what?

- Kirchhoff's current law gives us the relationship:

$$I_1 = I_2 + I_3$$

- Now apply Kirchhoff's voltage law to each of the three loops.

- The green loop: $9 = V_1 + V_2$ equation 1

The orange loop: $9 = V_1 + V_3$ equation 2

The blue loop: $0 = V_2 + V_3$

- Ohm's law gives us the relationships:

$$V_1 = I_1 \times R_1 = (I_2 + I_3) \times R_1$$

$$V_2 = I_2 \times R_2$$

$$V_3 = I_3 \times R_3$$

- Inserting the values of the resistors (in kΩ) gives:

$$V_1 = (I_2 + I_3) \times 1 = (I_2 + I_3)$$

$$V_2 = I_2 \times 10$$

$$V_3 = I_3 \times 2.2$$

- Using these, equation 1 becomes $9 = (I_2 + I_3) + (10 \times I_2)$

or $9 = 11I_2 + I_3$

which means that $I_3 = 9 - 11I_2$

and equation 2 becomes $9 = (I_2 + I_3) + (2.2 \times I_3)$

or $9 = I_2 + 3.2I_3$

Inserting the value of I_3 gives $9 = I_2 + 3.2(9 - 11I_2)$

so $(35.2 - 1)I_2 = 28.8 - 9$

which gives $I_2 = \mathbf{0.58mA}$

Substituting this in earlier equations $I_3 = 9 - 11I_2 = 9 - 11 \times 0.58 = \mathbf{2.63mA}$

and so $I_1 = 0.58 + 2.63 = \mathbf{3.21mA}$

In turn, these values give $V_1 = 3.21 \times 1 = 3.2V$

$$V_2 = 0.58 \times 10 = 5.8V$$

$$V_3 = 2.63 \times 2.2 = 5.8V \text{ (not surprisingly!)}$$

- Check your measured values against these results!

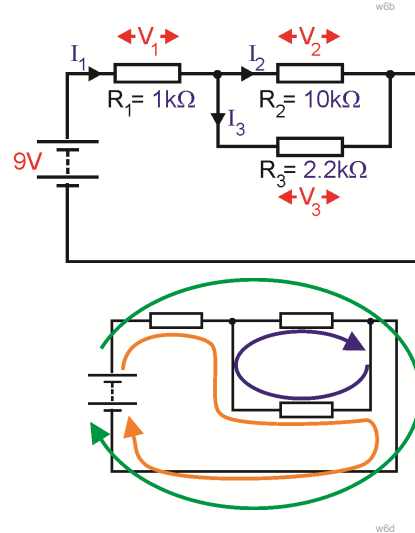

For your records:

- Kirchhoff's Current Law - 'What flows in must flow out'
The (vector) sum of all currents at any junction is zero.
- Kirchhoff's Voltage Law -
Around any loop in the circuit, the (vector) sum of voltages is zero.

Worksheet 7

Using the Superposition Theorem

In this worksheet you are going to examine the effect of each power source separately. Then, the voltages and currents caused by the separate power supplies are “superimposed” to find the actual voltages and currents, in the circuit containing the multiple power sources. In practice, all these values would be calculated, but this investigation takes actual measurements to check that the approach works.

Over to you:

Build the circuit shown opposite, but *do not switch on any power supplies yet!*

In three separate stages, measure currents and voltages:

1. using only the 9V power supply;
2. using only the 6V power supply;
3. using both power supplies.

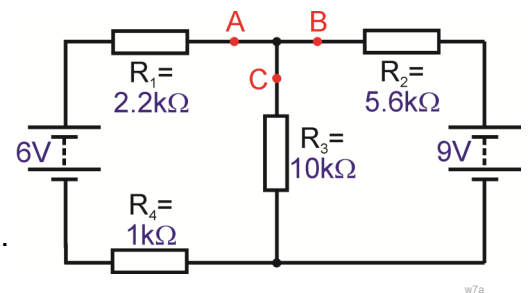

Step 1: Use only the 9V power supply

Replace the 6V power supply carrier with a connecting link.

Switch on the 9V power supply.

Use a multimeter, on the 2mA DC range, to measure the current at **A**, then at **B** and then at **C**, and record the values in the table. The directions of current flow have been added for you. Use a multimeter, on the 10V DC range to measure the voltage across the power supply, and then each resistor, and record the results in the table. The voltage directions (opposite to current flow, as current flows from a high voltage to a low voltage,) have been added for you.

Step 2: Use only the 6V power supply

Replace the 9V power supply carrier with a connecting link.

Return the 6V power supply and carrier, and switch on.

Repeat the measurements and record them in the table.

Add arrows to show the directions of currents and voltages.

Step 3: Use both power supplies

Reconnect both power supplies, and switch them on.

Measure the currents and voltages once more, recording the results in the table.

Add arrows to show the directions of currents and voltages.

Measurement	Step 1 - 9V supply only		Step 2 - 6V supply only		Step 3 - Both power supplies	
	Value	Direction	Value	Direction	Value	Direction
Current at A = I_A		←				
Current at B = I_B		←				
Current at C = I_C		↓				
Voltage across power supply, V_s		↑			Not needed	
Voltage across 1kΩ resistor, V_1		←				
Voltage across 2.2kΩ resistor, V_2		→				
Voltage across 5.6kΩ resistor, V_3		→				
Voltage across 10kΩ resistor, V_{10}		↑				

Worksheet 7

Using Superposition

So what?

- For steps 1 and 2, Kirchhoff's voltage rule applies, so using the symbols defined in the table on the previous page,

$$V_1 + V_2 + V_{10} = V_S$$
 and

$$V_1 + V_2 + V_5 = V_S$$
 Kirchhoff's current rule still applies so $I_A = I_B + I_C$
- For step 3, these rules also apply but we have to take direction into account. The diagrams show the directions of current flow for the circuits used in the first two stages.

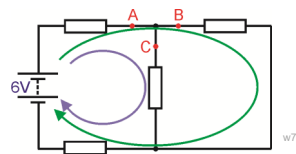
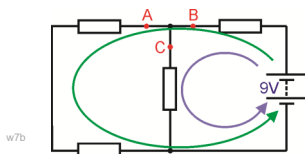

Step 1

Step 2

Notice that the current flows the same way through the 10kΩ resistor in both.

This means that when both power supplies are used:

- current at **C** = sum of separate currents due to the two power supplies
- voltage across the 10kΩ resistor = sum of separate voltages due to the two power supplies

In all other resistors, the current direction reverses between step 1 and step 2, so

current at **A** = **difference** between separate currents at **A** due to each power supply.

current at **B** = **difference** between separate currents at **B** due to each power supply.

V_1 = **difference** between separate V_1 voltages due to each power supply.

V_2 = **difference** between separate V_2 voltages due to each power supply.

V_5 = **difference** between separate V_5 voltages due to each power supply.

The direction of the current or voltage is the direction of the bigger component from step 1 or 2.

For example, here are a set of typical results:

Step 1: $I_A = 0.87\text{mA} \leftarrow I_B = 1.16\text{mA} \leftarrow V_2 = 1.95\text{V} \rightarrow V_5 = 6.54\text{V} \rightarrow$

Step 2: $I_A = 0.93\text{mA} \rightarrow I_B = 0.59\text{mA} \rightarrow V_2 = 2.08\text{V} \leftarrow V_5 = 3.36\text{V} \leftarrow$

When both power supplies are used:

$I_A = 0.06\text{mA} \leftarrow I_B = 0.57\text{mA} \leftarrow V_2 = 0.13\text{V} \leftarrow V_5 = 3.18\text{V} \rightarrow$

Look at the measurements you made. Check that the rules outlined above work for your results.



For your records:

To **calculate** the currents and voltages in a circuit that has more than one power source:

- replace all power sources but one with short-circuit links;
- calculate the currents and voltages caused by that remaining power source;
- do the same thing for each of the other power sources in turn;
- for each component, superimpose the currents and voltages from each separate power source (meaning that you must take into account the *direction* - add them when they are in the same direction - subtract smaller from bigger when they are in opposite directions.)

Worksheet 8

Using Thevenin's Theorem

Complex circuits, having large numbers of resistors and power sources, are difficult to analyse! It may be possible to work out the combined resistance of parallel resistors, and then combine that with the total of series resistors to arrive at the total resistance of the circuit. Then that could be used to work out the total current leaving the power source. Further calculations could work out how much current flows through each component, and what the voltage across it is.

In some cases, this procedure is not possible, because the resistor connections are not straightforward. The classic example of this is the bridge network, shown in the diagram.

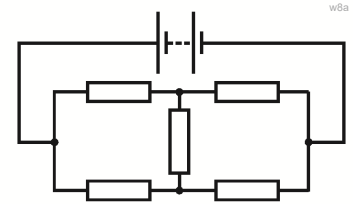

Thevenin's theorem offers a quick way forward in both of these cases. It states that any combination of voltage sources, current sources and resistors is electrically equivalent to a single voltage source in series with a single resistor.

Over to you:

Connect two 10kΩ resistors and a 15kΩ resistor, as shown in the circuit diagram. Set the power supply to 6V.

Set up the multimeter to read DC voltages of about 10V, and use it to measure the output voltage V_{OUT} with nothing else connected to the output. This is known as the *open-circuit output voltage*, V_{OC} . Record it in the table.

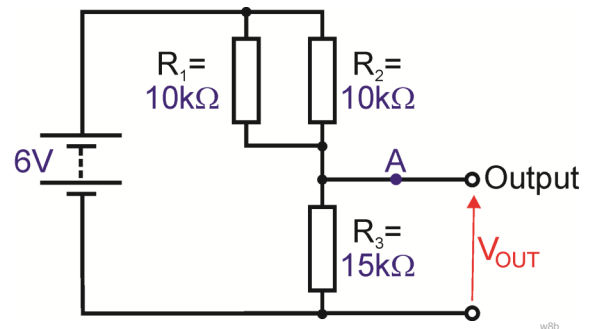

Set the multimeter on the 10mA DC range, and connect it to the output terminals. As ammeters have zero resistance ideally, this short-circuits the output. The reading you get is called the *short-circuit current*, I_{SC} . Record the value in the table.

Connect the following resistors across the output, i.e. in parallel with the 15kΩ resistor, in turn:

- a 330kΩ resistor;
- a 10kΩ resistor;
- a 270Ω resistor.

Each time, measure the output voltage, V_{OUT} , and the output current (the current at point A).

Record the results in the table.

Load	Measurement	Value
None	Open-circuit output voltage V_{OUT}	
	Short-circuit current I_{SC}	
330kΩ	Output voltage V_{OUT}	
	Output current I_{OUT}	
10kΩ	Output voltage V_{OUT}	
	Output current I_{OUT}	
270Ω	Output voltage V_{OUT}	
	Output current I_{OUT}	

Worksheet 8

Using Thevenin's Theorem



So what?

Thevenin's theorem says that the circuit you built, circuit A, is electrically equivalent to circuit B.

In other words, if both were enclosed in black boxes, with only the output sockets accessible, then no experiment you could perform could tell the difference between them.

To see this, first you need to use the component values given in circuit A to calculate V_{OC} and R_{EQ} :

1. What is the combined resistance of R_1 and R_2 , i.e. two $10k\Omega$ resistors, connected in parallel?

Answer

2. This combined resistance and R_3 , the $15k\Omega$ resistor, form a voltage divider.

Calculate the output voltage, which is actually V_{OC} , for this voltage divider.

$V_{OC} =$

3. If the output terminals were short-circuited, (connected together), this would remove the effect of the $15k\Omega$ resistor, leaving only the two $10k\Omega$ resistors to limit the output current. Calculate that current, i.e. the short-circuit output current, I_{SC} .

$I_{SC} =$

4. The theorem says that you would get exactly the same values for V_{OC} and I_{SC} in circuit B. If you short-circuit the output of circuit B, then the full voltage, V_{OC} , from the voltage source appears across the equivalent resistor, R_{EQ} , and the current flowing through it would be I_{SC} . Ohm's law then gives the value of R_{EQ} as:

$$R_{EQ} = V_{OC} / I_{SC}$$

Calculate the equivalent resistance R_{EQ} .

$R_{EQ} =$

5. Write your values for V_{OC} and R_{EQ} on the Thevenin equivalent circuit, shown opposite.

6. Use this circuit to calculate the output voltage, V_{OUT} , output current, I_{OUT} , when the following load resistors are connected across the output:

- (a) $330k\Omega$ (b) $10k\Omega$ (c) 270Ω

Write your answers in the table.

7. Check your measured values against these results!

Notice how much easier it was to calculate V_{OUT} and I_{OUT} in step 6, using the equivalent circuit, than using the procedure in steps 1 to 3. That's the merit of Thevenin's theorem!

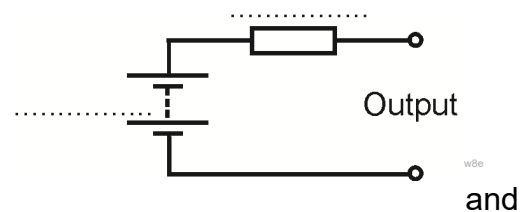
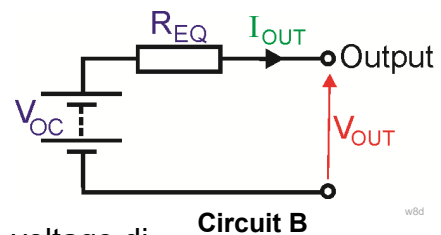
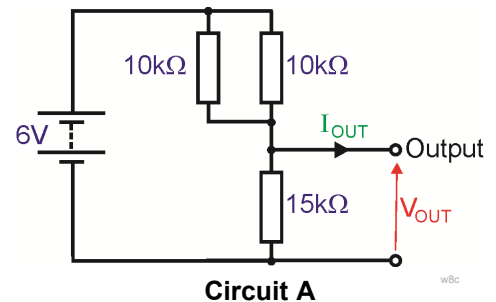

Load	V_{OUT}	I_{OUT}
$330k\Omega$		
$10k\Omega$		
270Ω		

Worksheet 9

Maximum Power Transfer



iStock_000010162335Small.jpg

There are two common situations in electrical systems. Often we want one subsystem to pass on a voltage signal to a subsequent subsystem. This is called voltage transfer. Occasionally, we want to transfer electrical power from one subsystem to the next. This happens at the end of an audio system, for example, where we want the loudspeakers to receive as much power as possible from the preceding driver subsystem.

The maximum power transfer theorem states that the maximum amount of power will be transferred from one subsystem to the next when the input resistance of the final subsystem is equal to the Thevenin equivalent resistance of the preceding one.

Over to you:

Connect two $10\text{k}\Omega$ resistors and a $15\text{k}\Omega$ resistor, as shown in the circuit diagram.

Set the power supply to 6V .

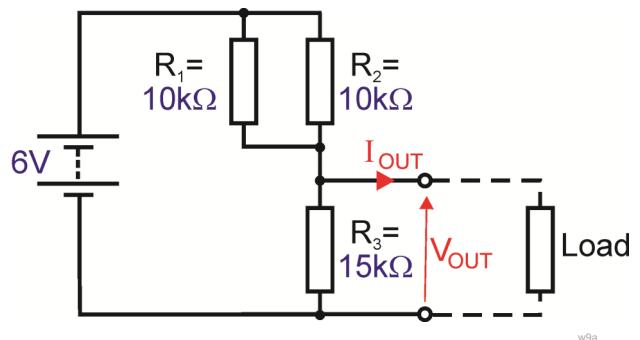

This is the same circuit you investigated in worksheet 8. There, you found that the Thevenin equivalent resistance of the circuit is $3.75\text{k}\Omega$.

Connect the first resistor listed in the table as a load for this circuit.

Use a multimeter, set to read DC voltages of about 10V , to measure the output voltage V_{OUT} .

Then set it on the 2mA DC range, measure the output current I_{OUT} .

Record your measurements in the table.

Repeat this procedure for each of the resistors in turn.

If you have one, set a variable resistor to a resistance of $3.75\text{k}\Omega$, (the equivalent resistance of the circuit,) and use it as the load. As before, measure the current through it and voltage across it.

Load Resistor	Output Voltage V_{OUT}	Output Current I_{OUT}
$1\text{k}\Omega$		
$2.2\text{k}\Omega$		
$5.6\text{k}\Omega$		
$10\text{k}\Omega$		
$22\text{k}\Omega$		
$3.75\text{k}\Omega$		

Worksheet 9

Maximum Power Transfer

So what?

- Power dissipated = current x voltage.
To dissipate a lot of power, both the current through the load and the voltage across it must be big. Look at your table of results. The voltage across the load is big when the load resistance is high. However, the current through the load is big when the load resistance is small!

- Use your measurements to calculate the power dissipated in the load, using $P = I_{OUT} \times V_{OUT}$ for each value of load resistor .
Complete the table with your results.

Load Resistor	Power Transferred = $I_{OUT} \times V_{OUT}$
1k Ω	
2.2k Ω	
5.6k Ω	
10k Ω	
22k Ω	
3.75k Ω	

- Plot a graph of your results, with 'Load' on the x-axis, and draw a smooth curve through your plotted points.

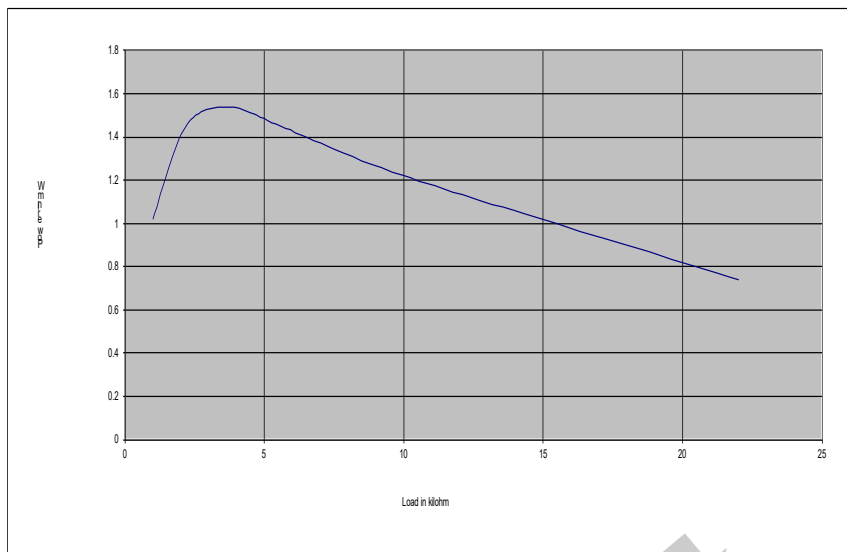

A graph of a typical set of results is shown here:

For your records:

Maximum power is transferred when the current through the load and the voltage across it are both big. However, the current is big when the load resistance is small, and the voltage across the load is big when the load resistance is big.

These conflicting requirements lead to:

Maximum power transfer theorem:

The maximum amount of power will be transferred from one subsystem to the next when the input resistance of the final subsystem is equal to the Thevenin equivalent resistance of the preceding one.

About this course

Introduction

The course is essentially a practical one. Locktronics equipment makes it simple and quick to construct and investigate electrical circuits. The end result can look exactly like the circuit diagram, thanks to the symbols printed on each component carrier.

Aim

The course introduces students to advanced concepts and relationships in electricity. It provides a series of practical experiments which allow students to unify theoretical work with practical skills in DC circuits.

Prior Knowledge

It is recommended that students have followed the 'Electricity Matters 1' and 'Electricity Matters 2' courses, or have equivalent knowledge and experience of building simple circuits, and using multimeters.

Learning Objectives

On successful completion of this course the student will:

- be able to recognise a series connection, and know that in a series circuit:
 - there is only one pathway for electrons to flow from one terminal of the power supply to the other;
 - the same current flows in all parts, as a result;
 - the power supply voltage is shared between all the components, so that the total voltage across all components is equal to the power supply voltage;
 - the effective resistance of three resistors connected in series is the sum of their individual resistances
$$R_T = R_1 + R_2 + R_3;$$
- be able to recognise a parallel connection, and know that in a parallel circuit:
 - the current is shared between all components connected in parallel, so that the sum of the currents through all parallel components equals the current leaving the power supply;
 - each component is connected directly to the two terminals of the power supply and so has the full supply voltage across it;
 - the total resistance, R_T of three resistors in parallel is:
$$1/R_T = 1/R_1 + 1/R_2 + 1/R_3$$
 - for two resistors in parallel, this reduces to:
$$R_T = \frac{R_1 \times R_2}{R_1 + R_2}$$
- be able to recognise a voltage divider, and know that:
 - the voltage from the power supply is shared between the components, so that $V_1 + V_2 = V_S$;
 - the bigger the resistor, the bigger its share of the voltage, so that $V_1 = k \times V_2$ when $R_1 = k \times R_2$;
 - it is usually best to use big resistor values, to reduce battery drain and power dissipation;
 - using lower resistor values allows us to draw more current from the voltage divider circuit without affecting the output voltage significantly;
- be able to recognise a current divider, and know that:
 - the current from the power supply is shared between the components, so that $I_S = I_1 + I_2$
 - the bigger the resistor, the smaller its share of the current so that $I_1 = 10 \times I_2$ when $R_2 = 10 \times R_1$;
- know Kirchhoff's Current Law - The vector sum of all currents at any junction is zero;
- know Kirchhoff's Voltage Law - Around any loop in the circuit, the vector sum of voltages is zero;
- be able to use the Superposition Principle to calculate currents and voltages for components in a complex circuit;
- be able to devise Thevenin's equivalent circuit for a network of resistors;
- be able to apply the maximum power transfer theorem.

What the student will need:

To complete this course the pupil will need the equipment shown in the table.

Qty	Code	Description
1	HP4039	Lid for plastic trays
2	HP6222	International power supply with adaptors
1	HP5540	Deep tray
1	HP7750	Locktronics daughter tray foam insert
1	HP9564	62mm daughter tray
1	LK2871	Locktronics Warranty Document
1	LK4000	Locktronics User Guide
1	LK4025	Resistor - 10 ohm, 1W 5% (DIN)
1	LK4065	Resistor - 47R. 1/4W 5% (DIN)
1	LK5100	Locktronics current probe
1	LK5202	Resistor - 1K, 1/4W, 5% (DIN)
3	LK5203	Resistor - 10K, 1/4W, 5% (DIN)
1	LK5205	Resistor - 270 ohm 1/4W, 5% (DIN)
1	LK5209	Resistor - 5.6K, 1/4W, 5% (DIN)
12	LK5250	Connecting Link
1	LK6201	Resistor - 330K, 1/4W, 5% (DIN)
2	LK6205	Capacitor, 1 uF, Polyester
1	LK6211	Resistor - 22K, 1/4W, 5% (DIN)
1	LK6213	Resistor - 15K 1/4W, 5% (DIN)
1	LK6214R2	Choke 47mH
1	LK6218	Resistor - 2.2K, 1/4W, 5% (DIN)
1	LK6492	Curriculum pack CD ROM
1	LK6917	Locktronics blister pack lid
1	LK6921	Locktronics blister pack clear tray & insert
2	LK7461	Power supply carrier with voltage source symbol
1	LK8022	General purpose lead set (LK5603 x 2, LK5604 x 2)
1	LK8900	7 x 5 baseboard with 4mm pillars

Power source:

Although there are two ways to power these circuits, either with C type batteries on a baseboard containing three battery holders, or using a mains-powered power supply, at this level the latter is more suitable, and the worksheets are written using that approach.

The larger baseboard is appropriate for use with this power supply., which can be adjusted to output voltages of either 3V, 4.5V, 6V, 7.5V, 9V or 12V, with currents typically up to 1A.

The voltage is changed by turning the selector dial just above the earth pin until the arrow points to the required voltage. The instructor may decide to make any adjustment necessary to the power supply voltage, or may allow students to make those changes.

The equipment list specifies two DC power supplies.

Worksheet 7 is the only one that requires both of these. The instructor may decide to use a battery or a mains-powered lab. supply as the second power source, or may ask students to share adjustable power supplies for that worksheet.



Using this course:

It is expected that the series of experiments given in this course is integrated with teaching or small group tutorials which introduce the theory behind the practical work, and reinforce it with written examples, assignments and calculations.

The worksheets should be printed / photocopied / laminated, preferably in colour, for the students' use. Students should be encouraged to make their own notes, and copy the results tables, working and sections marked 'For your records' for themselves. They are unlikely to need their own permanent copy of each worksheet.

Each worksheet has:

- an introduction to the topic under investigation;
- step-by-step instructions for the investigation that follows;
- a section headed 'So What', which aims to collate and summarise the results, and offer some extension work. It aims to encourage development of ideas, through collaboration with partners and with the instructor.
- a section headed 'For your records', which can be copied and completed in students' exercise books.

This format encourages self-study, with students working at a rate that suits their ability. It is for the instructor to monitor that students' understanding is keeping pace with their progress through the worksheets. One way to do this is to 'sign off' each worksheet, as a student completes it, and in the process have a brief chat with the student to assess grasp of the ideas involved in the exercises it contains.

Time:

It will take students between seven and nine hours to complete the worksheets.

It is expected that a similar length of time will be needed to support the learning that takes place as a result.

Worksheet	Notes for the Instructor	Timing
1	<p>The aim of the investigation is to justify the formula for series combinations of resistors.</p> <p>Students will have met series connections before, but it may be worth the instructor reminding them of equivalent transport phenomena, such as the flow of water, to drive home the issues involved. A series circuit has no junctions and no alternative routes from one terminal of the power supply to the other. As a result, the same current flows everywhere in that circuit, as it has nowhere else to go.</p> <p>As this may be the student's first experience of using the adjustable power supply, the instructor should check that it is set to the correct voltage, 4.5V.</p> <p>For those returning to electrical studies after a break, it is an opportunity to revisit the skills involved in using multimeters to measure current and voltage. In particular, students should be reminded that voltage measurements can be made without interrupting the circuit, as the multimeter is then connected in parallel with the resistor under investigation. On the other hand, to measure current at a point in the circuit, the circuit must be broken at that point and the multimeter inserted there to complete the circuit.</p> <p>Instructors need to be aware that the low current ranges on most multimeters are protected by internal fuses. If a student is having difficulty in getting readings from a circuit, it may be that this internal fuse has blown. It is worth having some spare multimeters available, and the means to change those fuses, to streamline the lesson.</p> <p>The students use their readings to measure the total resistance of the circuit and compare this with the value obtained from the series resistor formula.</p>	30 - 45 mins
2	<p>This is the equivalent to Worksheet 1 for parallel connections. Again, the vast majority of students will have already met the idea of parallel connections. These involve junctions in the circuit, allowing different currents to follow different routes from one terminal of the power supply to the other. It is worthwhile preparing students for this exercise by comparing the behaviour of water in an equivalent arrangement, where junctions in the pipes allow water to flow by different routes. Similarly, for traffic flow, a by-pass allows motorists to avoid narrow roads (high resistance) by choosing a dual-carriageway (low resistance.) Some will still prefer to miss the bustle of the busy by-pass by taking the narrow route.</p> <p>The activities are similar to those in Worksheet 1, and require similar multimeter skills. As before, the instructor should verify that the correct voltage has been selected on the power supply, and be prepared for multimeter problems resulting from a blown internal fuse.</p> <p>The measurements are processed in a similar way to that followed in Worksheet 1. The total resistance is obtained from the total current flowing, and the total voltage. The result is compared with that from the formula for parallel resistors.</p> <p>The summary gives two such formulae, one for combining just two resistors, and the other for combining any number. It may be worth setting the task of deriving the first of these from the second.</p> <p>The instructor should contrast the results with those from Worksheet 1. This time, the current through each resistor varies, but the voltage across each is the same. Previously, the current was the same, with different voltages across the resistors.</p>	30 - 45 mins

Worksheet	Notes for the Instructor	Timing
3	<p>This investigation combines the results developed in Worksheets 1 and 2, and applies them to a hybrid circuit containing some resistors in series and others in parallel.</p> <p>As before, this involves similar multimeter skills, and pitfalls. Instructors should again be aware of the internal fuse issue.</p> <p>The treatment compares measured values with calculated ones. Instructors might decide at this point to discuss component and instrument tolerance at this point. Inspection of the resistors beneath the carriers will show them to have either 5% or 1% tolerance. Measuring instruments have a range of accuracies, depending on what scale they are on. Students could be directed to manufacturer's data.</p> <p>The worksheet ends with a hybrid circuit for them to analyse. The outcome of their calculations will indicate how well they have assimilated the contents of the first three worksheets.</p>	25 - 40 mins
4	<p>Voltage dividers are a very important in electricity and electronics as they form the basis for many sensing subsystems, such as light-sensing units.</p> <p>They can also appear difficult to students. The aim here is to overcome that aura of difficulty by reducing the treatment to two simple stages:</p> <ul style="list-style-type: none"> • the sum of the voltages across the components equals the supply voltage; • the bigger the resistance of a component, the bigger its share of the supply voltage, so that if one resistor has four times the resistance of the other, it gets four times as much voltage. <p>This approach is tested with three different pairs of resistors, and using two supply voltages.</p> <p>The output voltage depends only the supply voltage and the relative size of the resistors, (not their absolute resistance,) so that a voltage divider made from a 2Ω and a 1Ω resistor behaves like one made from a $2M\Omega$ and a $1M\Omega$ resistor.</p> <p>However, the absolute values of resistance are important in two ways.</p> <ol style="list-style-type: none"> 1. Using very low values of resistance increases the current flowing through the voltage divider, and increases the power dissipation in the resistors. This is usually undesirable. 2. When another subsystem is connected to the voltage divider output, and draws an appreciable current, this extra loading can change the output voltage of the voltage divider. This extra current flows through the upper resistor but not the lower resistor in the voltage divider. A useful rule of thumb says that the current flowing through the unconnected voltage divider should be at least ten times bigger than the current that will be drawn from it when the next subsystem is connected to its output. <p>It may be worth discussing these points with the students once they have completed this exercise.</p>	25 - 40 mins

Worksheet	Notes for the Instructor	Timing
5	<p>This worksheet investigates current divider circuits, and compares and contrasts their behaviour with that just studied for voltage dividers.</p> <p>Current dividers do not have as many obvious applications as voltage dividers, though they are used in current measurement. It is often useful to measure only a fixed portion of the total current, and from that deduce the total current flowing. For example, if a current divider sends 10% of the total current through an ammeter, which then registers a current of 2.5A, then the total current flowing was 25A.</p> <p>In an approach parallel to that used for voltage dividers, the treatment looks at two simple ideas:</p> <ul style="list-style-type: none"> • the sum of the currents through the components equals the supply current; • the bigger the resistance of a component, the smaller its share of the current, so that if one resistor has four times the resistance of the other, it passes a current four times smaller. 	25 - 40 mins
6	<p>This worksheet looks at two very important, but straightforward, rules of electricity, known as Kirchhoff's laws. In the light of modern knowledge about electricity, these are less impressive than they would have appeared in 1845 when they were first formulated. Nevertheless, they offer valuable tools for analysing networks of components.</p> <p>The current law states that the (vector) sum of the currents at any point in a circuit is zero, or in other words, the total current flowing out of any junction is equal to the total current flowing into the junction. It may need to be stressed to students that it is vital to take into account the direction in which a current is flowing, as well as its magnitude, when applying Kirchhoff's rule. We can now say that it is a consequence of the conservation of charge, or, in other words, that electrons are neither created nor destroyed as they flow around a circuit.</p> <p>The voltage law says that around any loop in a circuit (any possible path that an electron may flow around,) the sum of the emf's (the effects giving energy to the electrons,) is equal to the pd's (the effects taking energy from the electrons. In other words, in a series circuit consisting of a 6V battery and two resistors, (so that there is only one possible loop,) the sum of the voltages across the resistors (which take energy from the electrons and heat up in the process, - the pd's) is equal to 6V (the battery gives energy to the electrons - the emf.) In reality, this rule is a restatement of the conservation of energy.</p> <p>The investigation looks at both these aspects, and takes measurements to justify them. There is a need for considerable practice in applying these, particularly the voltage rule, and it is suggested that the instructor should set several exercises where the student analyses the currents and voltages in a network using these laws.</p>	30 - 45 mins

Worksheet	Notes for the Instructor	Timing
7	<p>The idea behind the Superposition theorem is straightforward - that one power supply cannot know whether there are any others in the circuit. It offers us a powerful tool with which to analyse complex circuits. The approach is to find out what currents and voltages are set up by each power source in isolation, and then to combine these together using vector addition to take into account direction of current flow..</p> <p>The investigation requires two power sources. It is anticipated that students will use two Loctronics power supplies and carriers, perhaps borrowing one from another group. Where this is not possible, a 6V battery, or a mains powered lab. supply could be used instead. The assignment proceeds by removing one of the two power sources and replacing it with a conducting link. The student then measures the currents and voltages cause by this power source. Then the effect of the second power source is investigated in the same way. Finally, the values obtained for a particular component are combined to find the joint effect of the two power sources.</p> <p>The students may find the question of direction a difficult one, especially when it applies to voltage. The rule states that electric current flows from a region of high voltage to one of low voltage. (A useful analogy - under gravity, objects fall from high locations to lower.) Once the current direction is established, the direction of voltage follows straightaway - it's the opposite.</p> <p>The aim of the practical work is, once more, to justify the approach. In practice, the currents and voltages would be calculated, not measured. The students will require a number of examples illustrating the approach, and exercises for them to do themselves in order to fix the approach firmly in their minds.</p>	30 - 45 mins
8	<p>It can be extremely tedious and time consuming to do repeated calculations on a complex network of components. The accomplishment of Leon Thevenin, a French telegraph engineer, was to show, in the late nineteenth century, that these complex circuits can be reduced to much simpler ones to speed up those calculations.</p> <p>The Thevenin equivalent circuit consists of a power source and a single resistor in series with it. It comes into its own when the original complex circuit is attached to a load resistor of some kind. The idea is that the original circuit and the equivalent circuit have identical effects on that load. When the load changes, it is much easier to perform repeated calculations on the equivalent circuit than on the original. We think of the original circuit having two output terminals, onto which we will connect a variety of load resistors. The Thevenin equivalent circuit also has two output terminals. The behaviour of both is identical when the same load is attached to each. In other words, the same voltage is set up across the load, and the same current flows through it.</p> <p>The method looks at attaching loads at the extreme ends of the resistance spectrum, i.e. a short-circuit, and an open-circuit. In reality, these are an ammeter, which ideally has zero resistance, and a voltmeter, which ideally has infinite resistance. The reading on the first is called the short-circuit current, I_{SC}. The reading on the second is called the open-circuit voltage V_{OC}. Thevenin's theorem says that dividing the second by the first gives the equivalent resistance R_{EQ}. The investigation contrasts real measurements with calculated values to show that this approach works. As with earlier topics, there is no substitute for example after example of how this is applied to real circuits.</p>	30 - 45 mins

Worksheet	Notes for the Instructor	Timing
9	<p>It is important that students can distinguish between two situations.</p> <p>In one, a subsystem passes on a signal to the next as a varying voltage. Then it is important that as much of the voltage is transferred as possible. To achieve this, the input impedance (resistance in current terms,) of the second subsystem should be as high as possible, compared to the output impedance of the first subsystem. Ideally, the input impedance of the second stage should be infinite.</p> <p>This is known as the maximum voltage transfer theory.</p> <p>In the second situation, the aim is that the first subsystem passes on as much electrical power as possible in the signal. Since power = current x voltage, the ideal is to pass as high a current as possible, and as high a voltage as possible. These are conflicting requirements. For maximum current, the input and output resistances should be as small as possible. For maximum voltage, as pointed out in situation one, the input resistance should be as high as possible. The result is a compromise.</p> <p>The maximum power transfer theory says that the input impedance of the second stage should be equal to the output impedance of the first stage. In effect, this means that the maximum efficiency of this transfer is 50%. As much energy is dissipated in the output of the previous stage as in the second one.</p> <p>This is relevant in situations such as driving a loudspeaker as the final subsystem in an audio system. As much power as possible should be transferred to it to make it as loud as possible.</p> <p>The investigation uses a range of resistors as loads for the circuit used in Worksheet 8. There, Thevenin's theorem was used to obtain the output impedance (equivalent resistance R_{EQ} in this case.) For each load, students measure the voltage across and current flowing through the resistor, and use them to calculate the power dissipated (and so transferred) to the load. A graph of the results should point to maximum power transfer when the load resistance is equal to R_{EQ}. Where a variable resistor is available, this can be set to a value of R_{EQ} and used as one of the loads. This should yield the maximum value of power transferred.</p>	30 - 45 mins