



Simplifying Electricity

EASA - Electronic Fundamentals 4



LK7430

MATRIX
www.matrixmultimedia.com

Copyright © 2010 Matrix Multimedia Limited

Contents

Electronic fundamentals

4

Worksheet 1 - LVDT principles	3
Worksheet 2 - Controlling capacitive sensors	5
Optional investigation - Relaxation oscillator	7
Worksheet 3 - Motor controller	8
Worksheet 4 - Feedback control system	10
Revision Questions	12
Tutor's notes	14
Answers	20

Worksheet 1

LVDT principles

Electronic fundamentals

4

Linear variable differential transformers (LVDT) are widely used to sense position, for example of aircraft control surfaces, such as ailerons, elevators or rudders.

They produce an output signal containing information about direction and distance.

In this worksheet you will investigate the principle of a simple LVDT arrangement based on two inductively coupled coils.



w1a

Over to you:

- Build the circuit shown opposite.
- Ensure that the ferrite core is exactly centred in the two coil assembly.
- Connect the coils so that the output voltage rises when the core is moved one way, and falls when it is moved the other. The two possible ways to connect them are shown in the second diagram. (If incorrect, the voltage is a maximum when the core is central, and falls no matter which way the core moves.)
- Connect the input to a signal generator, set to give an output of between 10V and 20V peak-to-peak at a frequency of 2kHz.
- Set the meter to the 20V DC range.
- Slowly move the ferrite core first in one direction and then in the other. Watch what happens to meter reading as you do so.

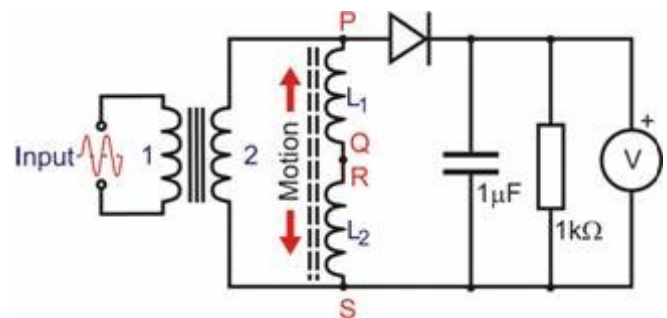

w1b

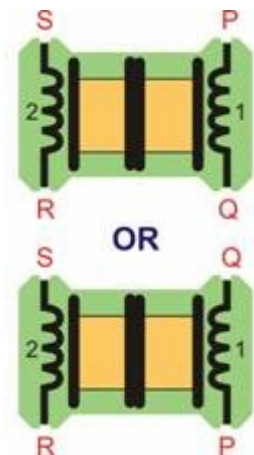

w1c

Further investigation:

- Connect a dual-trace oscilloscope to investigate the voltages induced in the two coils as the core is moved.
- To do so, connect the common terminal of the oscilloscope to point Q (or R). and the two channels to points P and S respectively.

Worksheet 1

LVDT principles

Electronic fundamentals

4

So what?

- The behaviour of the system should be like that shown in the graph opposite.

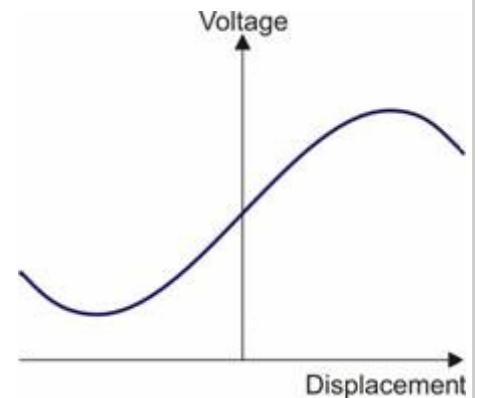

The LVDT is a miniature transformer with one primary and two secondary windings. The primary is centred between identical secondary coils.

The coil assembly is usually stationary. A ferrite or soft-iron core, attached to the sensor/actuator, moves inside the coils, as the sensor/actuator moves. Ideally, there is no physical contact between core and coil, and so no mechanical wear takes place.

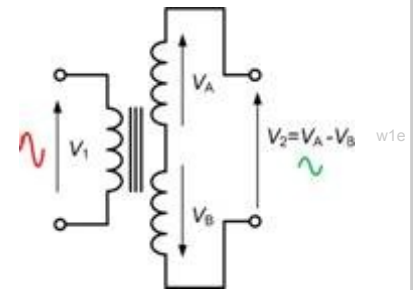

The LVDT requires an AC input, of a few volts amplitude with a frequency usually of a few kilohertz. This generates an alternating magnetic field, which is intensified in the core. This, in turn, induces an alternating voltage in the secondary coils. The greater the overlap of the core and the secondary coil, the greater the voltage induced.

The two secondary coils are connected in series in such a way that the induced voltages oppose each other. Thus the output voltage, V_2 , is zero when $V_A = V_B$. The phase of the output voltage indicates the direction in which the core has moved and the amplitude indicates how far it has moved. This AC output voltage is converted to a DC voltage by a rectifier circuit, and smoothing. The DC output can be sensed in a number of ways, the simplest being by a DC centre-zero meter.

For your records:

- Describe and explain the behaviour of the circuit in your own words.
- Does the LVDT produce a linear output and if so, over what range is it linear?
- How could the LVDT be improved? What would make it more sensitive?
- Suggest how the LVDT could be used in a position control system. What additional components and devices would be needed?

Worksheet 2

Controlling capacitive sensors

Electronic fundamentals

4

A wide variety of transducers are used to provide input signals to the control and servo systems used on a large aircraft.

Some sensors are inductive (as in the case of the LVDT) whilst others are resistive or use semiconductor sensing elements.

Capacitive transducers are widely used for fuel level sensing, but these usually involve small values of capacitance.

In this worksheet you will investigate the principle of operation of a capacitive sensor connected in a simple AC bridge circuit.



w2a

Over to you:

- Build the circuit shown opposite. The variable capacitor represents a capacitive sensor, such as a fuel-level sensor.
- It is connected in an AC bridge circuit. The output is rectified, and used to maintain a voltage across a capacitor. The 500k Ω 'bleed' resistor discharges the 1 μ F capacitor slowly.
- Connect the input to a signal generator, set to give an output of between 20V peak-to-peak at a frequency of 2kHz.
- Set the meter to the 2V DC range.
- Slowly adjust the variable capacitor.
- Watch what happens to voltmeter reading as you do so.

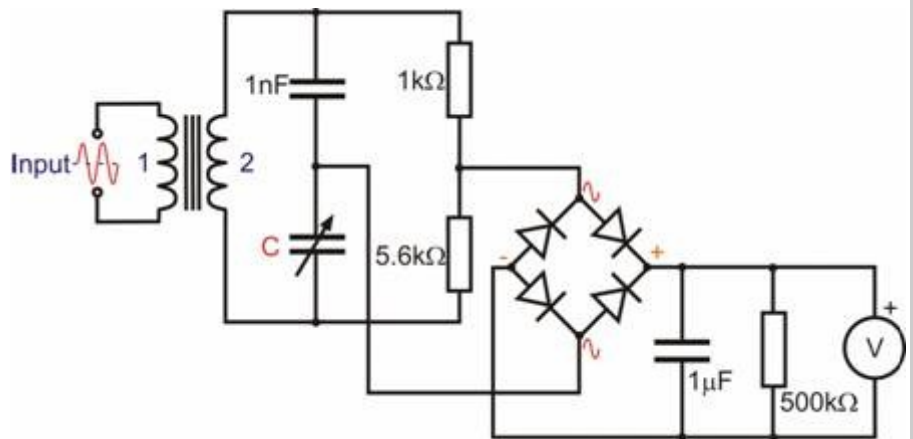

w2b

Further investigation:

- Connect an oscilloscope to investigate the voltages in the two 'halves' of the bridge as the variable capacitor is adjusted.
- To do so, connect the oscilloscope across the AC inputs to the bridge rectifier.
- Swap the 5.6k Ω resistor for a 10k Ω resistor, and repeat the investigation.

Worksheet 2

Controlling capacitive sensors

Electronic fundamentals

4

So what?

Bridge circuits:

are common circuit sub-systems, seen in a variety of forms.

The diagram shows the principle. Four devices, **A**, **B**, **C** and **D**, are arranged as two voltage dividers. One comprises **A** and **C**, the other **B** and **D**. They are 'bridged' by a sensing device, often a galvanometer **G** - a sensitive ammeter.

Equally, an output can be taken from the mid-points of the voltage dividers.

When the bridge is 'balanced', i.e. the galvanometer reads zero:

$$A/C = B/D$$

The input can be either a DC or an AC power supply. The devices **A** to **D** can be resistors, capacitors, inductors or combinations of these.

When the input is AC, and inductors or capacitors are involved, phase as well as magnitude must be taken into account. When magnitudes alone 'balance' there may still be a residual voltage across the null detection device.

Advantages of the bridge circuit include:

- the power supply voltage is irrelevant, as it is the same for both 'legs';
- the calibration of the galvanometer is irrelevant. All it has to do is detect current, not measure it.

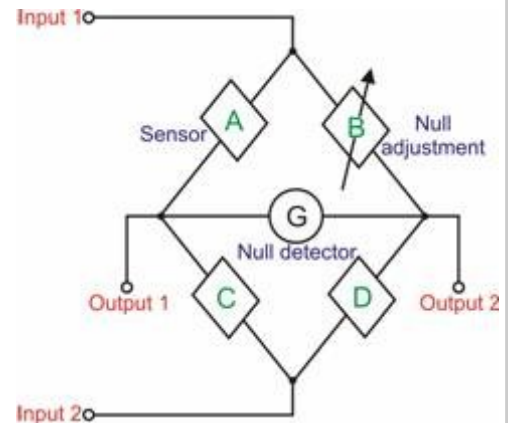

For your records:

- Describe and explain the behaviour of the circuit in your own words.
- Does the bridge produce a linear output and if so, over what range is it linear?
- How could the AC bridge be improved? What would make it more sensitive?
- Suggest how the capacitive sensor could be used in a fuel indicating system. What additional components and devices would be needed?
- Interpret the signals seen on the oscilloscope as the variable capacitor is adjusted.

Worksheet 2

Controlling capacitive sensors

Electronic fundamentals

4

Optional investigation:

The circuit built earlier turned capacitance changes into a voltage change.

Another approach uses a change in capacitance to change the frequency at which a circuit oscillates. This is the approach used in this optional investigation

Over to you:

- Build a relaxation oscillator, based on an op-amp. The circuit is shown below.

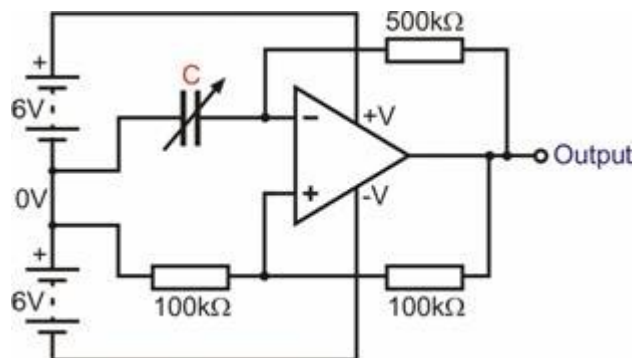

- Use two DC supplies, set to 6V DC, to power the circuit.
- Connect the output to an oscilloscope.
- Slowly adjust the variable capacitor.
- Observe the effect this has on the frequency of oscillation, displayed on the oscilloscope.
- You could use a frequency meter to monitor the effect.

Further investigation:

- The output can be rectified, using either a half-wave diode pump arrangement, like that shown on page 3, or a full-wave bridge rectifier, like that shown on page 5. The output can then be monitored on a DC voltmeter.

Worksheet 3

Motor controller

Electronic fundamentals

4

Motors are widely used as output transducers in aircraft control systems, and so are motor controllers.

These control both speed and direction of rotation. This can be achieved using a motor controller based on nothing more than a pair of transistors and an operational amplifier.

In this worksheet you will investigate the operation of a simple 'open loop' motor controller, meaning that it uses no feedback.



w3a

Over to you:

- Build the circuit shown opposite.
- Use two DC power supplies, set to 6V, plugged into the dual-rail power supply carrier, to supply the +6V / 0V / -6V power rails.
- Two light emitting diodes, connected in 'anti-parallel', indicate the polarity of the output voltage supplied to the motor, and so also the direction of rotation of the motor - either clockwise or anti-clockwise.
- Set the 'pot' to produce an output of 0V. (The motor should not be running.)
- Vary the setting of the 'pot', first in one direction and then in the other and notice the effect on the motor and the two LED indicators.

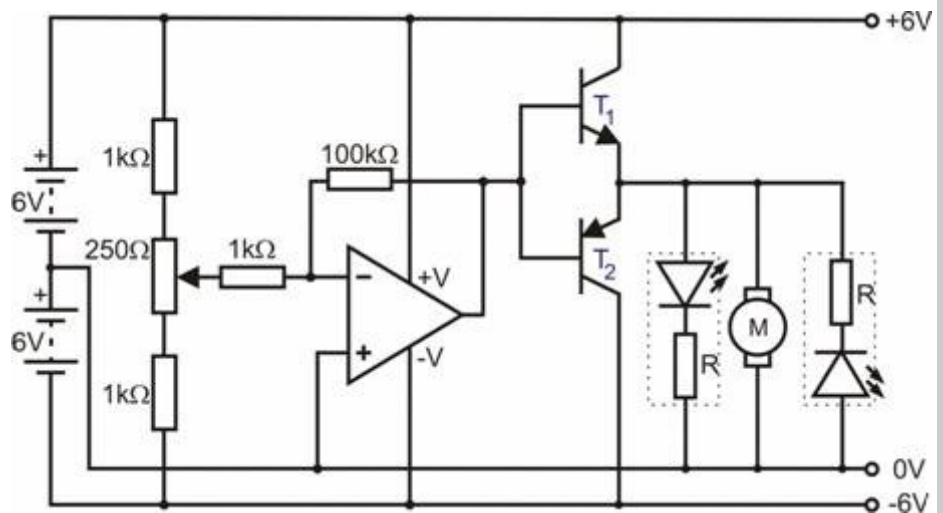

w3b

Worksheet 3

Motor controller

Electronic fundamentals

4

So what?

- The op-amp is set up as an inverting amplifier, with a voltage gain of 100x. Its input impedance is around $1\text{k}\Omega$ - i.e. relatively small, and so it affects the voltage taken from the sensing unit, the 'pot'.
- Transistors T_1 and T_2 form a push-pull follower, investigated in an earlier module. They copy the input voltage to the output and are capable of delivering sufficient current to drive the motor.
- The power supply is set up to create, ostensibly, a $+6\text{V} / 0\text{V} / -6\text{V}$ split power supply. The op-amp and output stage are referred to 0V. The output of the transistors can swing above and below this system reference voltage.
- There is no feedback loop to inform the system just how fast the motor is turning, or if it is turning at all, or even if there is a motor attached! This limitation will be addressed in the next worksheet.
- This kind of controller is not energy-efficient, for two reasons. The 'pot' and balancing $1\text{k}\Omega$ resistors have current flowing through them at all times, and so dissipate energy. The transistors 'follow' the input voltage. When the output of T_1 is $+2\text{V}$, the rest of the $+6\text{V}$ supply, i.e. 4V , is dropped across the transistor. The transistor can be delivering substantial current to the motor, and so is dissipating significant energy itself.

For your records:

- Explain, in your own words, how the circuit works.
- Over what approximate range of adjustment of the variable resistor does the motor remain stationary?
- Does the motor move in both directions? How do you know this?
- Does the variable resistor provide effective control of the speed? Is it possible to adjust the speed so that the motor runs slowly and consistently at the same speed?
- How could the motor controller be improved? What would make it provide smoother control of speed?
- Suggest how the motor controller could be used in a practical aircraft application. What additional components and devices would be needed?

Worksheet 4

Feedback control system

Electronic fundamentals

4

Earlier, you saw the limitations of 'open loop' motor control.

There is no automatic comparison of the actual output value with the desired value, and no compensation for any differences.

Modern aircraft systems use 'closed loop' control systems, in which negative feedback is used to regulate the system. In most cases this is fully automatic. The only human intervention is setting the desired output value.

In this worksheet you investigate the behaviour of a system with and without this feedback.

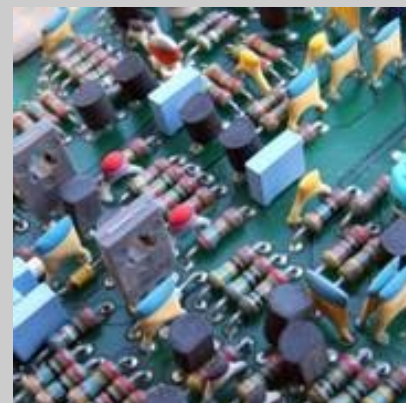

w4a

Over to you:

- Build the circuit shown opposite.
- Again, use two DC power supplies, set to 6V, plugged into the dual-rail carrier, to supply the +6V / 0V / -6V power rails.
- A 100Ω resistor acts as a 'load'. The voltage developed across it is measured using the meter set to the 20V DC range.
- The link at the input can be set to either position A or B. In position A, no feedback is provided and so the control system operates in open-loop mode. In position B negative feedback is provided and the system operates in closed-loop mode.
- Set the link to position A. Turn the 'pot', first in one direction and then in the other and notice the effect on the DC output voltage. Record the range of output voltage produced,
- Now do the same with the link set to position B.
- Finally, repeat these steps with the 100Ω load removed. Once again, record the range of output voltage for both open-loop and closed-loop operation.

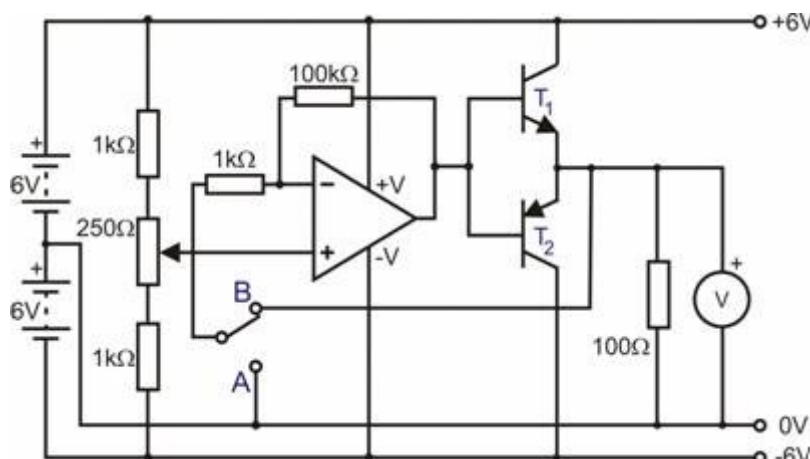

w4b

Open-loop operation	100Ω load	No load	Closed-loop operation	100Ω load	No load
Max. output voltage			Max. output voltage		
Min. output voltage			Min. output voltage		

Worksheet 4

Feedback control system

Electronic fundamentals

4

So what?

The diagram shows the difference between open-loop and closed-loop control systems:

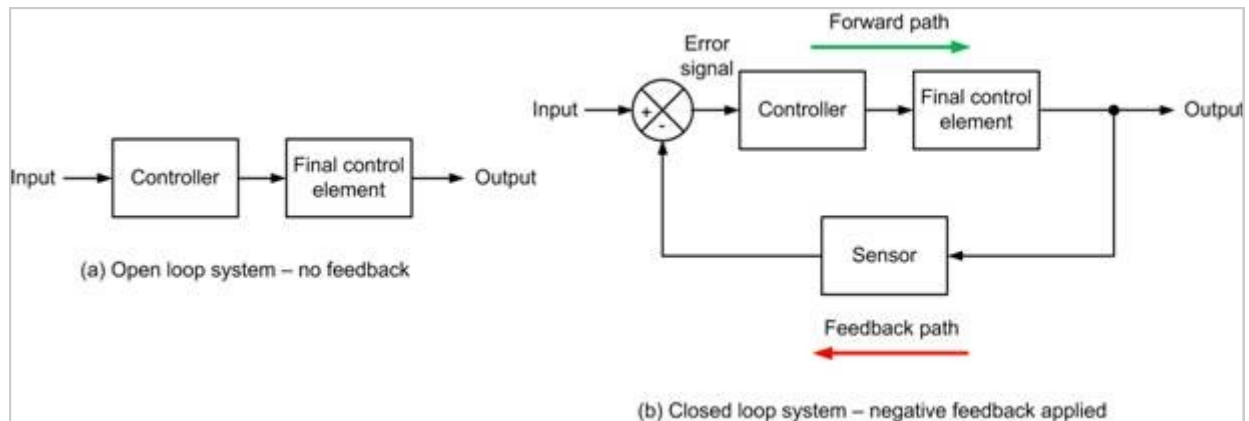

This difference can be illustrated by reference to the 'cabin' heating system inside a car.

In an open-loop control system, the driver turns the temperature control to a likely position, and waits. If the cabin is too hot, the driver turns the temperature control down. If too cold, the driver, turns it up. The actual temperature inside the car depends on the outside temperature, and on the temperature of the water circulating in the heater. It is up to the driver to make appropriate adjustment to take account of these.

In a closed-loop control system, the driver sets the desired temperature. A temperature sensor in the cabin feeds back information on the current temperature to the heating system. When the actual temperature is below the set temperature, the heating system warms up the cabin. When the temperature is above the set value, the heating system turns off, or even cools down the cabin. The only intervention by the driver is to set the desired temperature.

For your records:

- Explain, in your own words, how the circuit works.
- Comment on the results obtained for both open-loop and closed-loop operation of the system. Which configuration provided the smoothest control of the output?
- Which configuration produced the greatest output change and which produced the least? Why was this?
- Which configuration maintained an output that was more constant with and without the load connected? Why was this?

Questions

Electronic fundamentals

4

About these questions

These questions are typical of those that you will be required to answer in the EASA Part-66 examination.

You should allow 15 minutes to answer these questions and then check your answers with those given on page 19.

Please remember that **ALL** these questions must be attempted **without** the use of a calculator and that the pass mark for all Part-66 multiple-choice examinations is 75%!

1. What type of excitation is used with a linear variable differential transformer (LVDT) ?

- (a) alternating current (AC)
- (b) direct current (DC)
- (c) no excitation is required.

2. What type of excitation is used with a capacitive bridge transducer?

- (a) alternating current (AC)
- (b) direct current (DC)
- (c) no excitation is required.

3. Which one of the following is an application of an LVDT?

- (a) fuel level sensing
- (b) position sensing
- (c) airspeed sensing.

4. In a control system, an increase in velocity feedback will:

- (a) decrease the speed the load moves
- (b) increase the speed the load moves
- (c) have no effect on the speed.

5. In a speed control system, velocity feedback can be obtained from a:

- (a) tachogenerator
- (b) transformer
- (c) potentiometer.

6. In a control system, a reduction in velocity feedback will:

- (a) decrease the speed the load moves
- (b) increase the speed the load moves
- (c) have no effect on the speed.

7. In a control system, positional feedback can be obtained from a:

- (a) tachogenerator
- (b) transformer
- (c) potentiometer.

w2b

w2b

Questions

Electronic fundamentals

4

8. The type of feedback used in a servo control system is:

- (a) negative feedback
- (b) positive feedback
- (c) control systems don't use feedback.

9. If the electrical connections to the feedback generator in a control system are reversed, the:

- (a) motor would run in the wrong direction
- (b) input signal to the amplifier would be reduced
- (c) the system would become unstable.

10. The connection marked 'X' in the symbol is the:

- (a) inverting input
- (b) non-inverting input
- (c) positive supply rail.

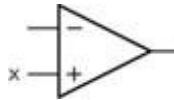

rq1

11. The component shown is:

- (a) a ring modulator
- (b) a summing junction
- (c) a bridge rectifier.

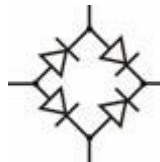

rq2

12. When negative feedback is applied in a system:

- (a) the overall gain is increased
- (b) the overall gain is reduced
- (c) there is no change in the overall gain.

13. Which one of the following is an application of a capacitive bridge sensor?

- (a) fuel level sensing
- (b) position sensing
- (c) airspeed sensing.

14. The function of an operational amplifier within a feedback system is to:

- (a) form the error signal
- (b) supply power to the output transducer
- (c) convert the AC feedback signal to equivalent DC

15. Which a bridge is balanced the output voltage will be:

- (a) zero
- (b) equal to the positive supply
- (c) equal to the negative supply.

Answers are provided on page 19

Tutor's notes

Electronic fundamentals

4

About this course

Introduction

This workbook is intended to reinforce the learning that takes place in the classroom or lecture room. It provides a series of practical activities and investigations that complement syllabus section 4.3 of EASA Part-66 Module 4, Electronic Fundamentals.

Locktronics equipment makes it simple and quick to construct and investigate electrical circuits. The end result can look exactly like the circuit diagram, thanks to the symbols printed on each component carrier.

Aim

The workbook aims to introduce students to the basic underpinning principles and concepts of aircraft electrical and electronic equipment. It also provides a useful introduction to electrical measurements and the use of ammeters, voltmeters and oscilloscopes.

Prior Knowledge

Students should have previously studied (or should be concurrently studying) EASA Module 3 (Electrical Fundamentals) or should have equivalent knowledge at Level 3.

Learning Objectives

On successful completion of this course the student will have learned:

- the structure and operating principles of a typical linear variable differential voltage transformer (LVDT);
- how a LVDT can be used to sense linear position;
- how capacitive transducers are used to sense fuel levels;
- how sensors and transducers are connected in an AC bridge configuration;
- the advantages of using bridge networks;
- how the linearity of a transducer is affected by physical constraints;
- how open and closed-loop servo control systems operate and the essential differences between them;
- how negative feedback can be used to improve the performance of a servo control system;
- how operational amplifiers can be used as an error forming device;
- how push-pull transistors can be used to increase load current in a servo system.

Tutor's notes

Electronic fundamentals

4

What students will need:

This pack is designed to work with the Locktronics Aircraft Maintenance Kit. The electrical / electronic parts required for this workbook are listed on the next page.

Students will also need:

- either two multimeters, such as the LK1110, capable of measuring currents in the range 0 to 200mA, and voltages in the range 0 to 200V;
- or equivalent ammeters and voltmeters.

For other modules in the series, they will need:

- a function generator, such as the LK8990, or equivalent;
- and an oscilloscope capable of monitoring the signals it produces, such as the LK6730 Pico 4000 virtual oscilloscope.

If you are missing any components, or need additional items, please contact Matrix or your local dealer.

Power sources:

Students will need to make use of an adjustable low-voltage DC supply. The output voltage from the supplied DC power unit can be adjusted to provide outputs of either 3 V, 4.5 V, 6 V, 7.5 V, 9 V or 13.5V, with currents typically up to 1 A. The voltage is changed by turning the selector dial just above the earth pin until the arrow points to the required voltage.

Tutors may decide to make any adjustment necessary to the power supply voltage, or may allow students to make those changes.

Each exercise includes a recommended voltage for that particular circuit.

In the example opposite, the DC power supply has been adjusted to provide an output of 13.5V DC.



p28a

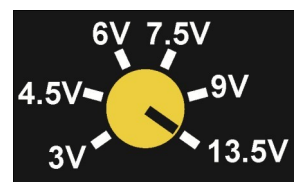

p28b

Tutor's notes

Electronic fundamentals

4

The table on the right shows the parts needed for all 4 workbooks in the Electronic fundamentals series.

Qty	Code	Description
1	HP3728	AC power supply, 12VAC, 1.5A, UK
1	LK2340	AC voltage source carrier
1	LK3982	Voltmeter, 0V to 15V
1	LK4002	Resistor, 100 ohm, 1W, 5% (DIN)
1	LK4003	Capacitor, 1,000 uF, Electrolytic 30V
1	LK4123	Transformer, 2:1 turns ratio
1	LK4663	Low power solar motor
3	LK5202	Resistor, 1k, 1/4W, 5% (DIN)
3	LK5203	Resistor, 10k, 1/4W, 5% (DIN)
1	LK5205	Resistor, 270 ohm, 1/2W, 5% (DIN)
2	LK5207	Resistor, 180 ohm, 1/2W, 5% (DIN)
1	LK5208	Potentiometer, 250 ohm (DIN)
2	LK5214	Potentiometer, 10k (DIN)
2	LK5218	Resistor, 100k, 1/4W, 5% (DIN)
2	LK5224	Capacitor, 47uF, Electrolytic, 25V
1	LK5240	Transistor RHF, NPN
1	LK5241	Transistor LHF, NPN
1	LK5242	Diode, germanium
3	LK5243	Diode, power, 1A, 50V
1	LK5247	Zener diode, 4.7V
1	LK5248	Thyristor
12	LK5250	Connecting Link
1	LK5254	Zener diode, 8.2V
1	LK5255	Transistor RHF, PNP
1	LK5256	Transistor LHF, PNP
1	LK5266	Bridge rectifier
1	LK5402	Thermistor, 4.7k, NTC (DIN)
2	LK5603	Lead, red, 500mm, 4mm to 4mm stackable
2	LK5604	Lead, black, 500mm, 4mm to 4mm stackable
2	LK5607	Lead, yellow, 500mm, 4mm to 4mm stackable
2	LK5609	Lead, blue, 500mm, 4mm to 4mm stackable
1	LK6202	Capacitor, 100uF, Electrolytic, 25V
1	LK6205	Capacitor, 1 uF, Polyester
4	LK6206	Capacitor, 4.7uF, electrolytic, 25V
2	LK6207	Switch, push to make, metal strip
1	LK6209	Switch, on/off, metal strip
1	LK6214	Capacitor, VARIABLE, 0-200pF
3	LK6216	Capacitor, 0.47 uF, Polyester
1	LK6218	Resistor, 2.2k, 1/4W, 5% (DIN)
1	LK6224	Switch, changeover, toggle
1	LK6232	Resistor, 500k, 1/4W, 5% (DIN)
1	LK6234L	Op Amp Carrier (TL081) with 2mm to 4mm Leads
1	LK6238	Resistor, 200k, 1/4W, 5% (DIN)
1	LK6239	Capacitor, 1nF, Polyester
2	LK6635	LED, red, 5V (SB)
1	LK6706	Motor 3 to 12V DC, 0.7A
1	LK6860	AND gate carrier (ANSI)
1	LK6861	OR gate carrier (ANSI)
2	LK6862	NOT gate carrier (ANSI)
1	LK7409	AA battery holder carrier
1	LK7483	1:1 transformer with retractable ferrite core
2	LK8275	Power supply carrier with battery symbol
1	LK8492	Dual rail power supply carrier
2	LK8900	7 x 5 metric baseboard with 4mm pillars
2	LK9381	Ammeter, 0mA to 100mA

Tutor's notes

Electronic fundamentals

4

Using this course:

It is expected that the worksheets are printed / photocopied, preferably in colour, for the students' use. Students should retain their own copy of the entire workbook.

Worksheets usually contain:

- an introduction to the topic under investigation and its aircraft application;
- step-by-step instructions for the practical investigation that follows;
- a section headed 'So What?' which aims both to challenge learners by questioning their understanding of a topic and also provides a useful summary of what has been learned. It can be used to develop ideas and as a trigger for class discussion.
- a section headed 'Questions' which provides further work for students to carry out. Answers to these questions are provided at the end of this workbook.

This format encourages self-study, with students working at a rate that suits their ability. It is for the tutor to monitor that students' understanding is keeping pace with their progress through the worksheets and to provide additional work that will challenge brighter learners. One way to do this is to 'sign off' each worksheet, as a student completes it, and in the process have a brief chat with each learner to assess their grasp of the ideas involved in the exercises that it contains.

Finally, a set of examination 'Revision Questions' has been provided to conclude the work on each topic. These questions are of mixed difficulty and are typical of those that students will face when they sit their Module 4 CAA examinations. It is recommended that students should attempt these questions under examination conditions and without the use of notes or calculators.

Time:

It will take most students between eight and ten hours to complete the full set of worksheets. It is expected that a similar length of time will be needed to support the learning in a class, tutorial or self-study environment.

Tutor's notes

Electronic fundamentals

4

Worksheet	Notes for the Tutor	Timing
1	<p>In this worksheet learners will investigate the principle of a simple linear variable differential transformer (LVDT).</p> <p>LVDT's are widely used as a means of sensing the position of the load (such as a control surface) driven by an actuator. The LVDT usually comprises a miniature transformer with two secondary windings and a moving ferrite or soft-iron core attached to a plunger. In this investigation, the LVDT comprises two inductively coupled coils fed in series with an AC supply. Due to the frequency of excitation and relatively low value of inductance of the individual coils, the adjustable core should take the form of a ferrite rod rather than an iron or steel core.</p> <p>Students will require a waveform generator that produces a sinusoidal output of at least 10V peak-peak and with an output impedance of 50Ω, or less. In addition, they will require a voltmeter capable of reading 20V full-scale.</p> <p>Students should find that the linear range of the LVDT under investigation is quite small—about 20mm. They should be able to relate this to the physical dimensions of the coil assembly.</p> <p>Before they tackle this worksheet, students will benefit from an introduction to the LVDT and its application as a linear position sensor. Practical aircraft applications could also usefully be discussed.</p>	45 - 60 minutes
2	<p>Having met the LVDT, this worksheet introduces students to another type of transducer, the variable capacitance transducer. Capacitive transducers are widely used for fuel level sensing and the signals that they provide are essential to the aircraft's fuel management system.</p> <p>Students will investigate the principle of operation of a capacitive sensor connected in a simple AC bridge circuit.</p> <p>Students will once again require a waveform generator that produces a sinusoidal output of around 20V peak-peak and with an output impedance of 50Ω, or less. In addition, they will require a voltmeter capable of reading 2V full-scale.</p> <p>Students should find that the linear range of the bridge is quite small and for very low values of capacitance may also be affected by stray capacitance associated with the wiring.</p> <p>However, it should be stressed that absolute linearity is not essential as fuel level is also affected by tank dimensions and calibration will be necessary to correct for this.</p> <p>At the end of the worksheet, there is an introduction to bridge circuits. These are normally 'balanced' so that the output is zero initially. The one investigated here is different, in that it is always imbalanced. The 'Further Investigation' allows the students to examine a balanced bridge. It may be necessary to disconnect the bridge rectifier arrangement to 'unload' the capacitance bridge.</p>	45 - 60 minutes

Tutor's notes

Electronic fundamentals

4

Worksheet	Notes for the Tutor	Timing
<p>2 cont...</p>	<p>An optional investigation follows in which students construct a relaxation oscillator based on an op-amp. When the variable capacitor is adjusted, the frequency of oscillation changes. This is observed directly on an oscilloscope connected to the output. More able students can investigate the effect of changing resistor values, though they should be warned that the voltage gain of the op-amp falls significantly at high frequencies.</p>	
<p>3</p>	<p>DC motors are widely used as output transducers in aircraft control systems. In this worksheet students will investigate the operation of a simple DC motor controller. This arrangement provides control for both speed and direction but it operates without negative feedback and thus provides students with an example of an open-loop system.</p> <p>Prior to this investigation, students should be reminded about work that they have previously carried out on operational amplifiers, push-pull transistor output stages, and light-emitting diodes. They should also be given an introduction to the basic concepts of 'open-loop' and 'closed-loop' systems.</p> <p>In order to provide the positive and negative supply rails, students will require two 6V DC power supplies. They should ensure that the common connection is taken to the operational amplifier's 0V supply rail.</p> <p>Due to the lack of negative feedback, students should find that precise adjustment of motor speed is extremely difficult and may require repeated adjustments. They should also notice the dead-band over which the motor remains stationary and the rapid increase of speed either side of this range. These are all characteristics of open-loop systems and students should be able to observe them without any additional prompting.</p>	<p>60 - 90 minutes</p>
<p>4</p>	<p>In this final worksheet students investigate the operation of a system which can be configured as either an open-loop system or a closed-loop system. They will also be able to make some comparative measurements on the system that shows how it behaves with and without feedback applied.</p> <p>As with the previous worksheet, students will require two separate 6V DC power supplies. Rather than use a motor as a load (as in the previous worksheet) the output of the control system is applied to a 100Ω resistor.</p> <p>In order to configure the control system in either open-loop or closed-loop mode, the inverting input of IC1 can be either connected directly to 0V (open-loop) or to the output (closed-loop), using the changeover switch. These are marked as links A and B respectively in the circuit diagram.</p> <p>Student should measure the range of output voltage produced when driving a 100Ω load both with and without feedback applied. They should then repeat this with no load applied.</p> <p>From the measurements that they make, they should be able to deduce that:</p> <ul style="list-style-type: none"> • the overall voltage gain of the system is significantly reduced when feedback is applied (i.e. closed-loop) • the change in output voltage, with and without a load applied, is significantly reduced when feedback is applied (i.e. closed-loop). 	<p>60 - 90 minutes</p>

Answers

Electronic fundamentals

4

Revision question paper

1. (a)
2. (a)
3. (b)
4. (a)
5. (a)
6. (b)
7. (c)
8. (a)
9. (c)
10. (b)
11. (c)
12. (b)
13. (a)
14. (a)
15. (a)