

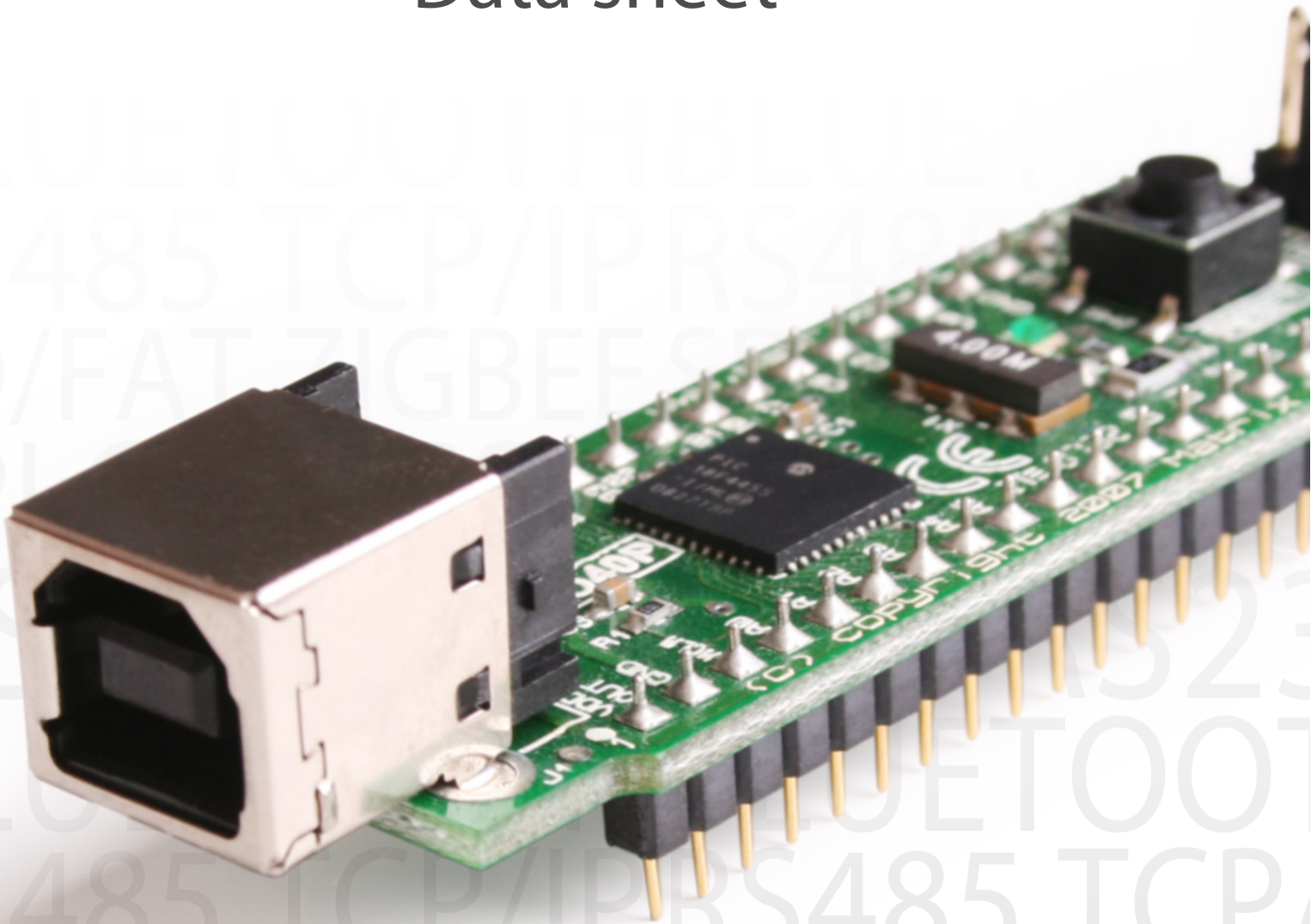

## Data sheet



# Contents

Introduction	3
ECIO28P and ECIO40P	4
ECIO40P16	5
ECRM40P	6
Flowcode	7
ECIO in use	8
FlowKit In Circuit Test board	9
Product codes and ordering	10

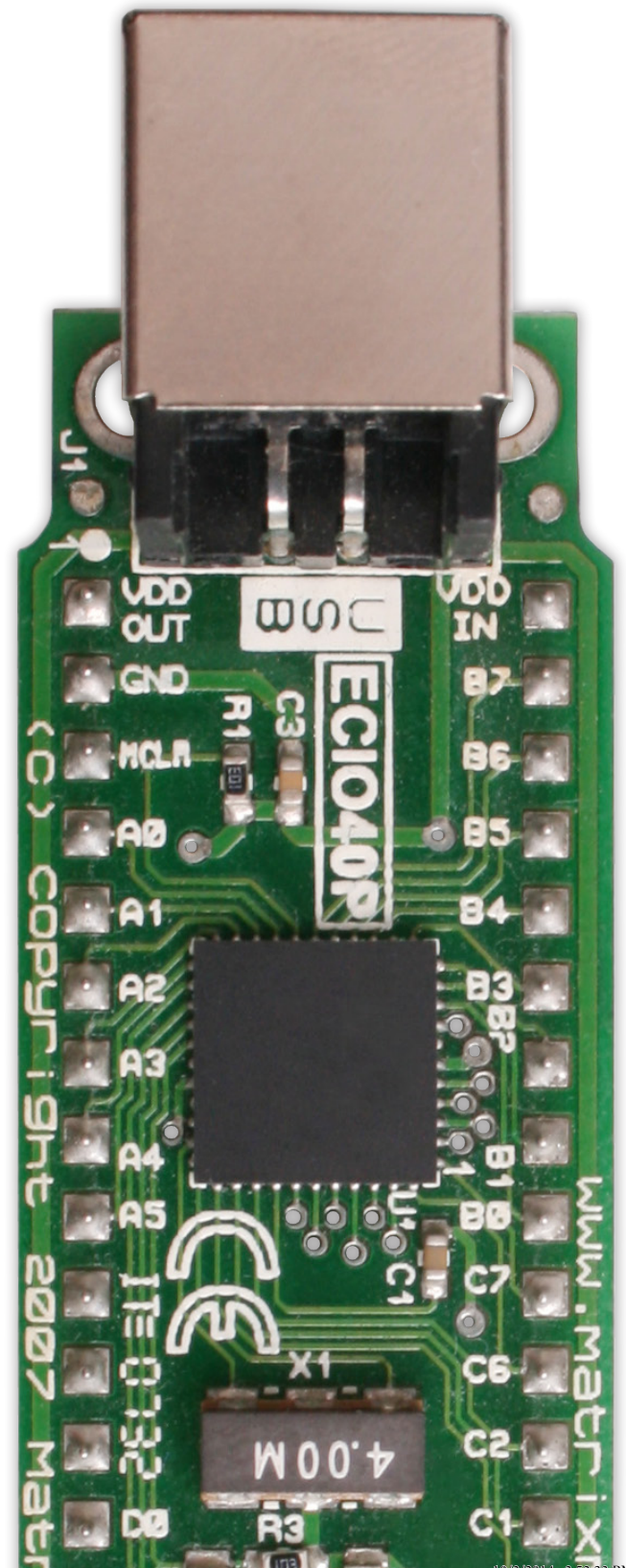

# Introduction

ECIO devices are powerful USB programmable microcontrollers with 28 and 40 pin DIL (0.6") footprints.

## Benefits

- Allow you to add USB programmability to your projects
- Low cost microcontroller programming, platform for development and learning

## Features

- Programmable from USB
- Includes bootloader software
- Can draw power from USB
- Usable with LabView, Visual Basic, C++ etc.

The ECIO family of USB programmable microcontrollers provides an incredibly simple way of adopting microcontroller technology into your projects. The device behaves just like a normal microcontroller - but when you plug the USB lead in and press the reset switch you can send a new program to the device. This makes the ECIO one of the lowest cost USB programmers in the world.

Currently there are four products in the range: ECIO28P, ECIO40P, ECIO40P16 and ECRM40. ECIO28P and ECIO40P devices are based on PICmicro 18 series devices - the

18F2455 and the 18F4455 respectively. The ECIO40P16 is based on the dsPIC33EP256MU806. The ECRM40 is based on the Atmel AT91 ARM 7 processor.

ECIO microcontrollers are pre-programmed with a bootloader program which allows you to send a new program to the microcontroller via USB. ECIO is compatible with hex code from any appropriate compiler. ECIOs are directly compatible with Flowcode - a graphical programming language which greatly simplifies the code generation process - but can also be used with any C compiler.

ECIO is suitable for use where direct programming from USB is required: for projects, or where systems need reprogramming in the field.

ECIO is well supported with a wide range of learning and development tools including Flowcode and E-blocks.

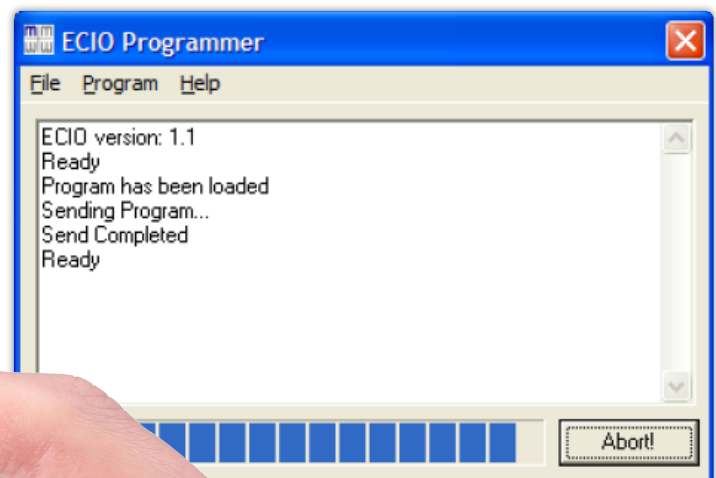

[Download software](#)

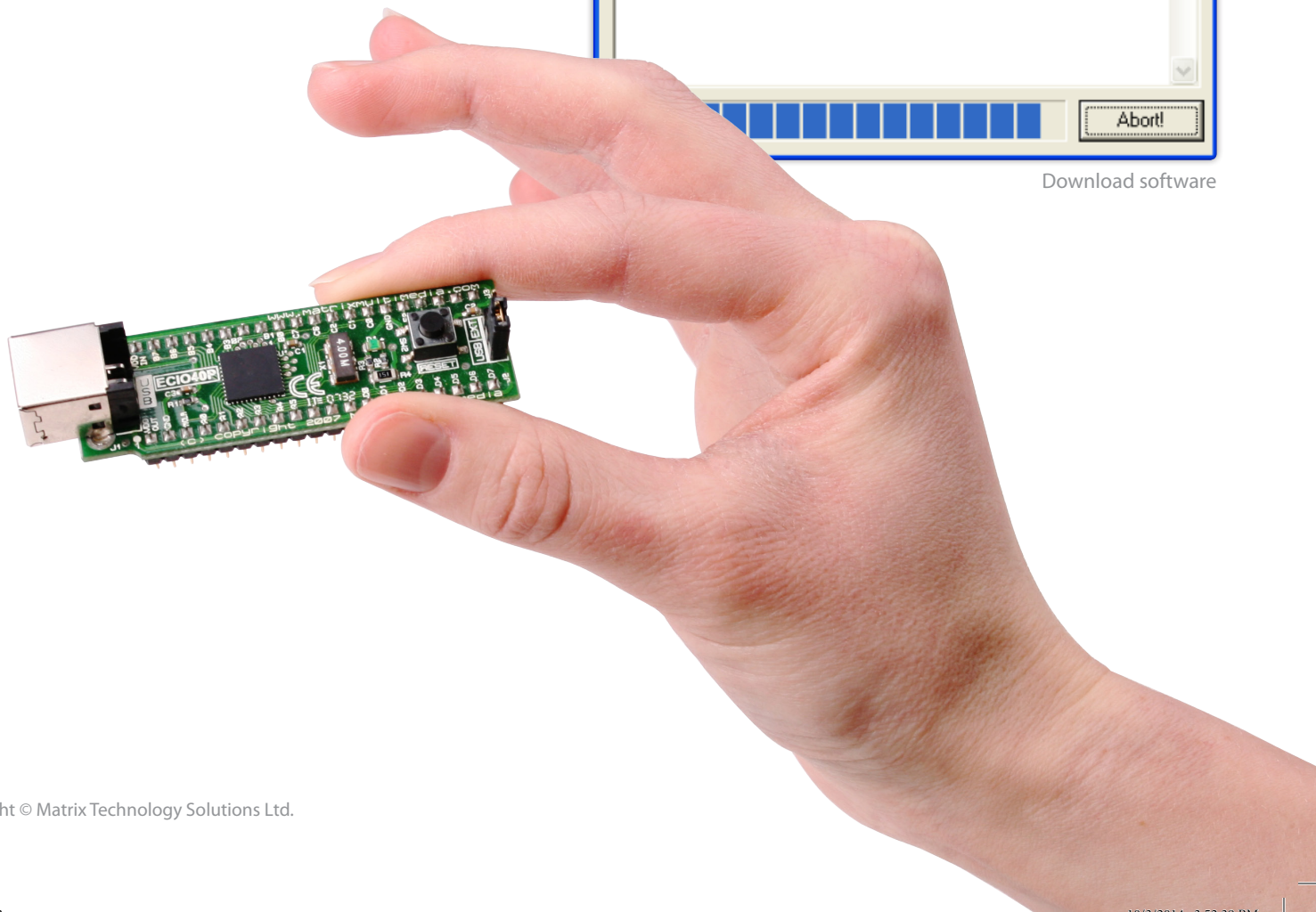

# ECIO28P and ECIO40P

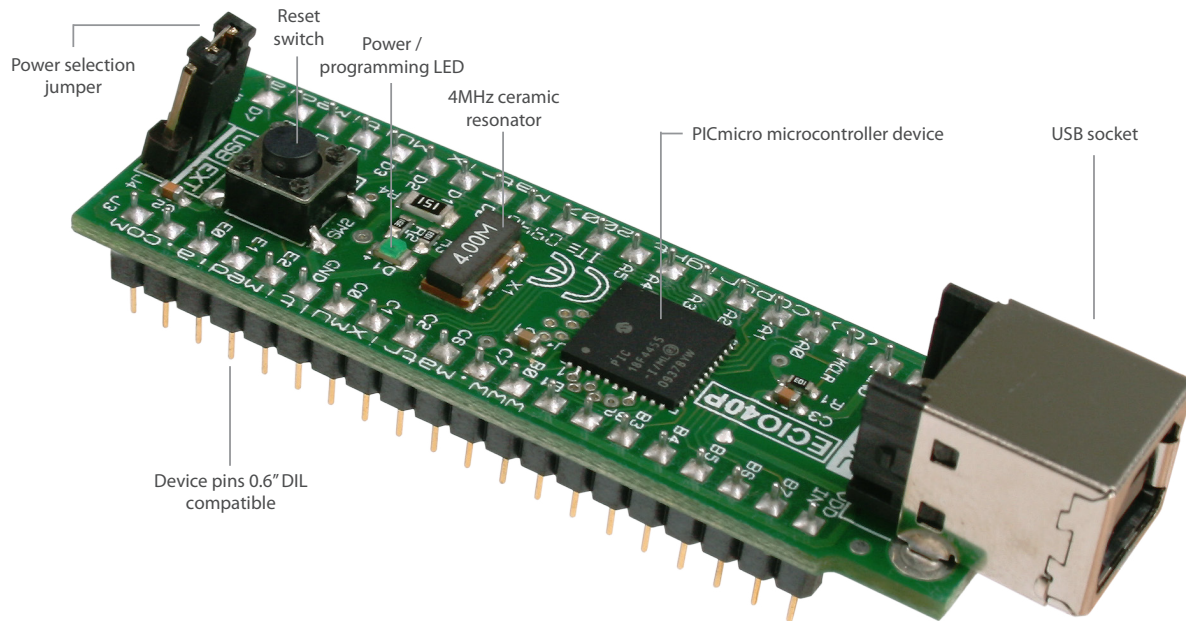

## ECIO40P

Processor	8 bit 18 series PICmicro
Base chip	PIC18F4455
Oscillator	4MHz ext., 48MHz internal
I/O lines	30
A/D	13 x 10 bit
A/D sample rate	100ksps
Program memory	24K bytes
RAM	2K bytes
EEPROM	256 bytes
Power	5V, USB or external
PWM channels	2
Timers	1 x 8 bit, 3 x 16 bit
Interfaces	EUSART, MI <sup>2</sup> C, SPI, USB2.0
Package	40 pin DIP, 0.6" compatible

## ECIO28P

Processor	8 bit 18 series PICmicro
Base chip	PIC18F2455
Oscillator	4MHz ext., 48MHz internal
I/O lines	19
A/D	10 x 10 bit
A/D sample rate	100ksps
Program memory	24K bytes
RAM	2K bytes
EEPROM	256 bytes
Power	5V, USB or external
PWM channels	2
Timers	1 x 8 bit, 3 x 16 bit
Interfaces	EUSART, MI <sup>2</sup> C, SPI, USB2.0
Package	28 pin DIP, 0.6" compatible

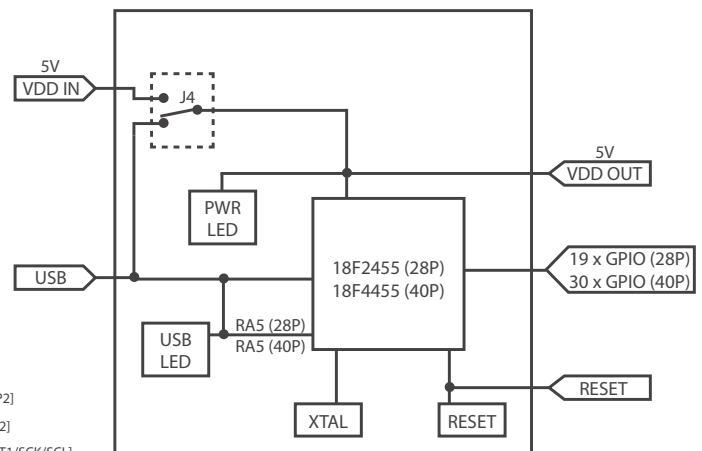
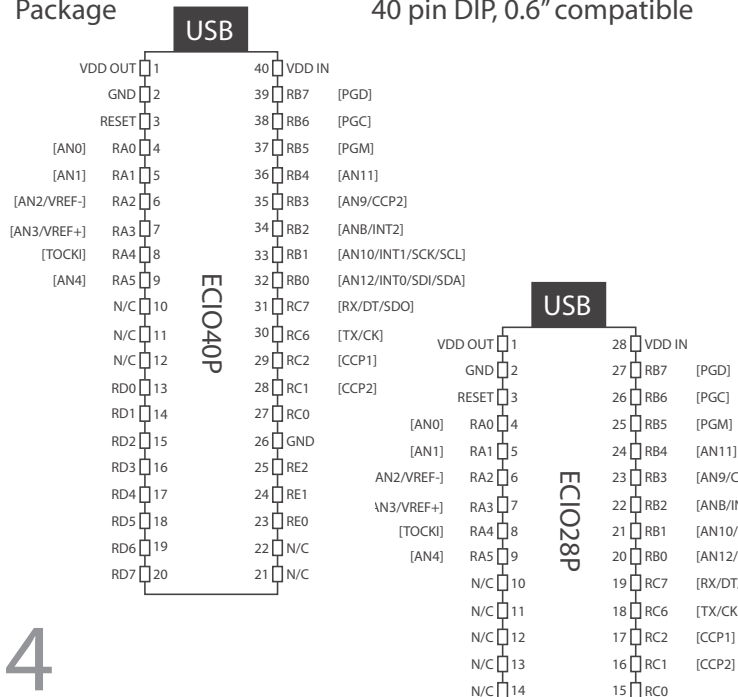

ECIO28P/40P block diagram

Copyright © Matrix Technology Solutions Ltd.

# ECIO40P16

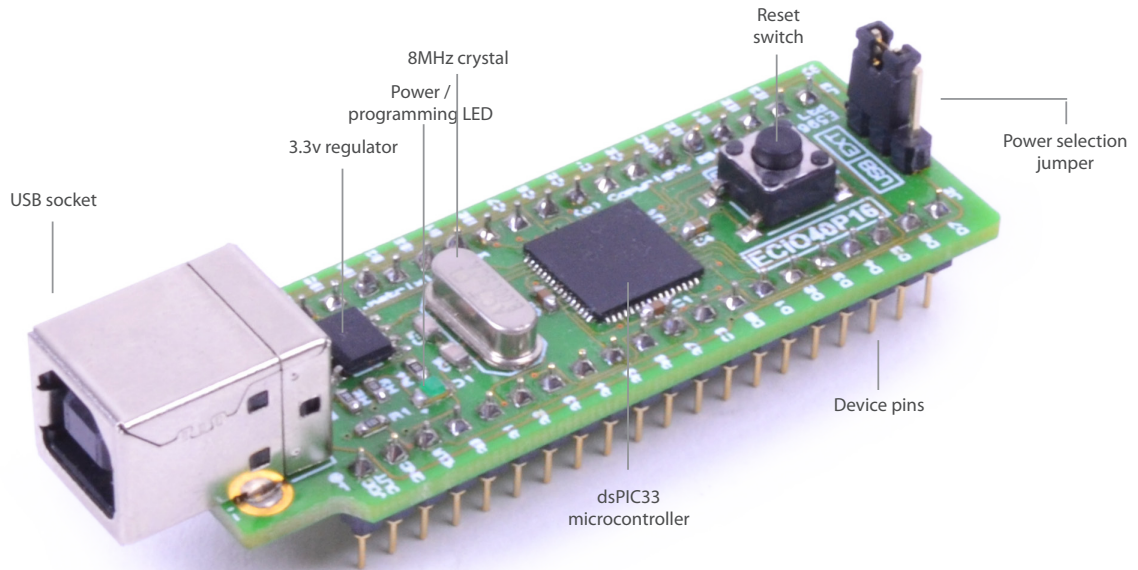

## ECIO40P16

Processor	16 bit, dsPIC33
Base chip	dsPIC33EP256MU806
Oscillator	8MHz ext., 70MHz internal
I/O lines	34
A/D	20 x 12 bit
A/D sample rate	1.1 Msp/s
Program memory	256K bytes
RAM	28K bytes
EEPROM	0 (internal ROM overwrite)
Power	5V, USB or external
PWM channels	16
Timers	9 x 16 bit
Interfaces	4 x UART, 2 x MI <sup>2</sup> C, 4 x SPI, 2 x CAN, USB2.0
Package	40 pin DIP, 0.6" compatible

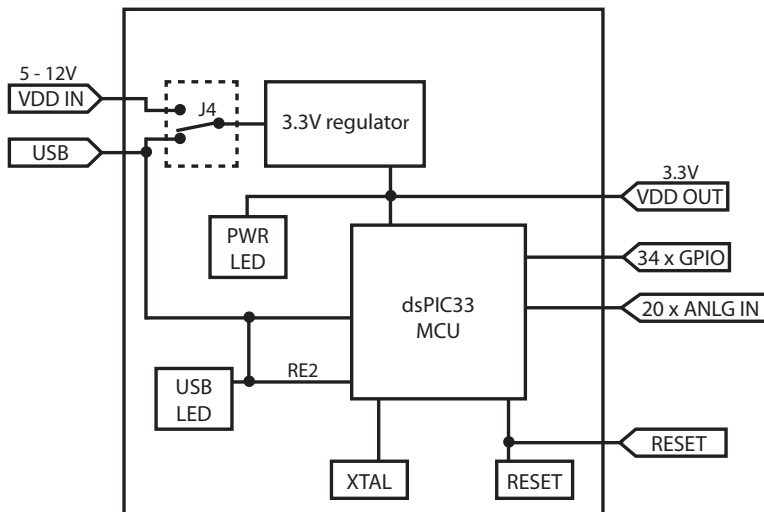
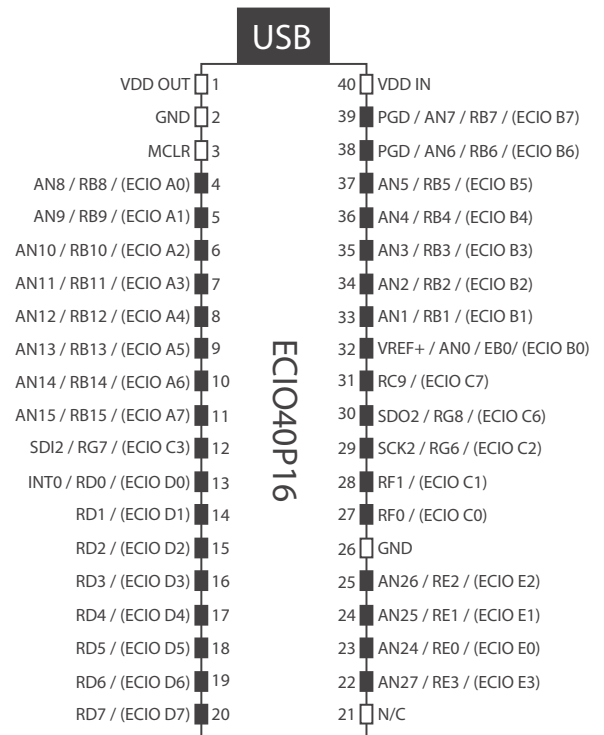

# ECRM40P

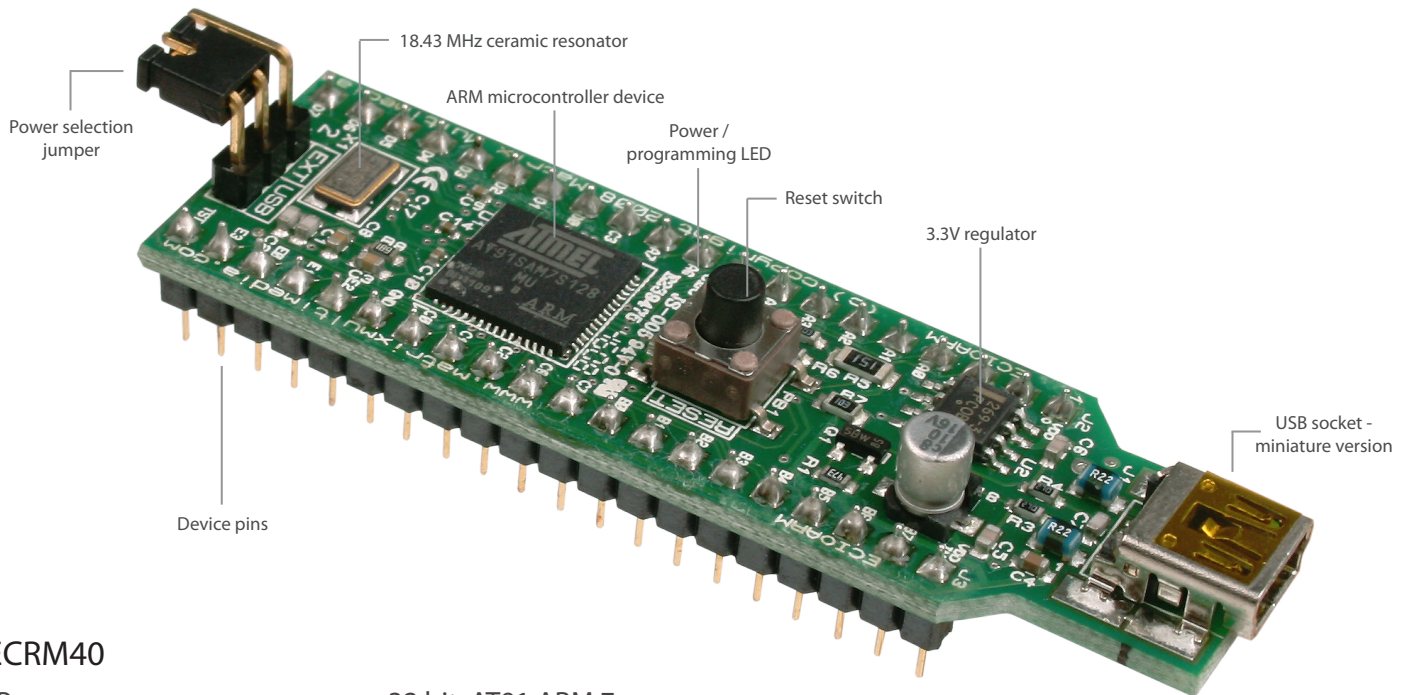

## ECRM40

Processor	32 bit, AT91 ARM 7 core
Base chip	AT91SAM7SI28
Oscillator	18.43MHz ext., 47.92MHz internal
I/O lines	34
A/D	8 x 10 bit
A/D sample rate	300ksps
Program memory	128K bytes
RAM	32K bytes
EEPROM	0 (internal ROM overwrite)
Power	5V, USB or external
PWM channels	4
Timers	3 x 16 bit, 2 x 32 bit
Interfaces	2 x EUSART, MI <sup>2</sup> C, SPI, USB2.0
Package	40 pin DIP, 0.6" compatible

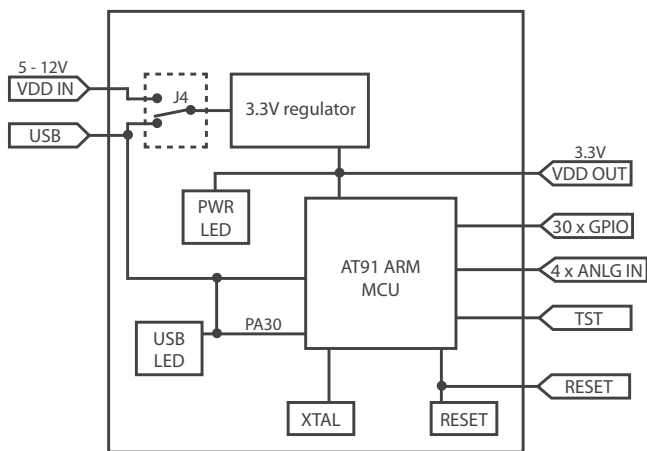
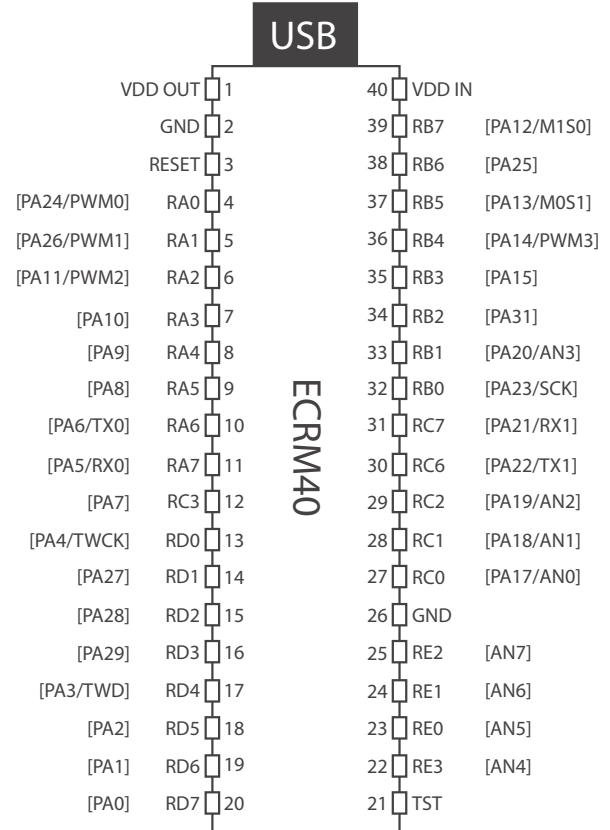

ECIO ARM block diagram

# Flowcode

ECIO devices are fully compatible with Flowcode - one of the world's most advanced graphical programming languages for microcontrollers.

The great advantage of Flowcode is that it allows those with little experience to create complex electronic systems in minutes. Flowcode achieves this in three steps: firstly users drag and drop flowchart symbols onto the screen, and fill in the dialogue boxes when prompted. Then users can simulate the program within Flowcode and view the results on the simulation panel. Finally, Flowcode compiles the flowchart into code that is downloaded to a PICmicro microcontroller which executes the program.

Flowcode is available in twenty languages, including English, Finnish, French, German, Italian, Dutch and Spanish.

## Design

Flowcode contains standard flowchart icons and electronic components that allow you to create a virtual electronic system on screen. Drag icons and components onto the screen to create a program, then click on them to set properties and actions.

- Easy to use interface
- Allows complex programs to be developed and managed quickly
- All I/O and expansion options are supported in Flowcode

## Simulate

Once your system is designed you can use Flowcode to simulate it in action. Test the system's functionality by clicking on switches or altering sensor values, and see how your program reacts to the changes in the electronic system.

- Simulation aids understanding
- Debug before download
- Shorten the design cycle

## Download

When you are happy with your design, click one button to send the program directly to the ECIO device. Remove the USB lead and press the reset button and your program starts to run.

- One button download
- Compiles to C and Assembly
- Link in your own C files

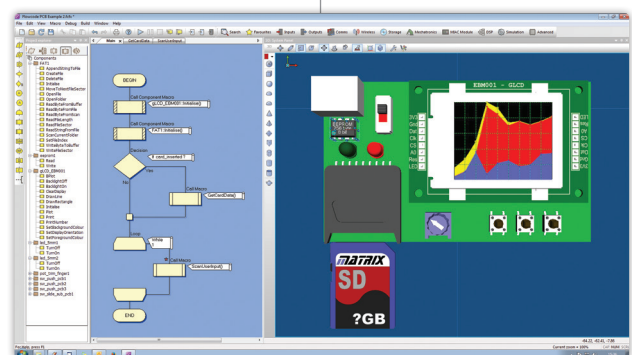
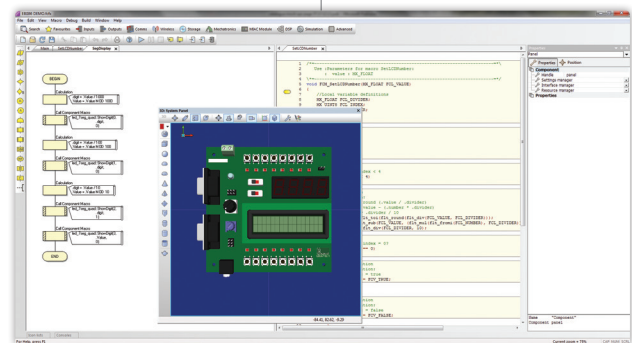
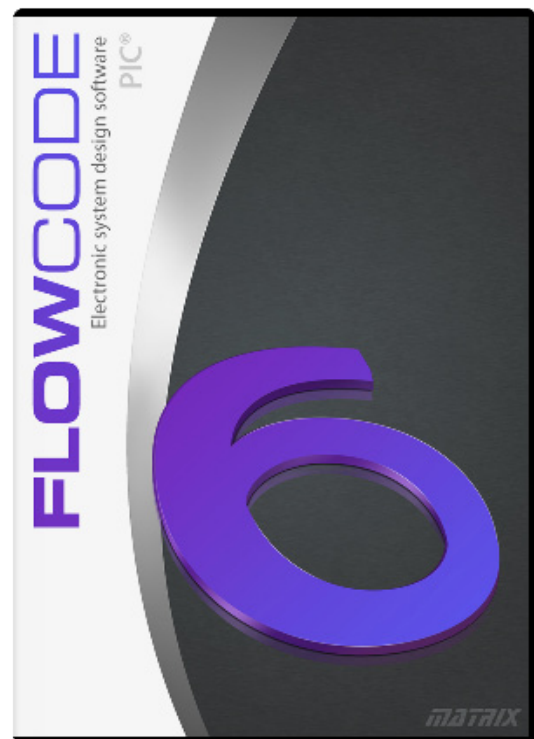

# ECIO in use

There are several ways of using the ECIO:

## With a prototype board

ECIO devices are really useful when used in conjunction with a prototype board: the ECIO unit simply plugs into the matrix of holes and the surrounding components are wired in using single strand wire. The ECIO can be used with an external power supply or the unit can draw power from the USB lead itself.

## With E-blocks

If you have larger projects, or you want to connect more advanced systems together, then you can use the E-blocks adaptor panel (EB061) shown here. This allows you to connect a large range of boards from simple LEDs and switches through to CAN sub-systems etc. This is ideal for prototyping larger and more complex systems.

## With your own hardware

If you are developing your own hardware you can use the ECIO board as a component: adding ECIO to your system allows you to develop a product that can be reprogrammed in the field.

## Use with LabView, Visual Basic and other packages

ECIO can easily be integrated with third party PC based control packages like LabView and Visual Basic. This is

enabled by a DLL and a suite of sample programs that can be downloaded to the ECIO to provide a fully controllable slave device from PC based applications.

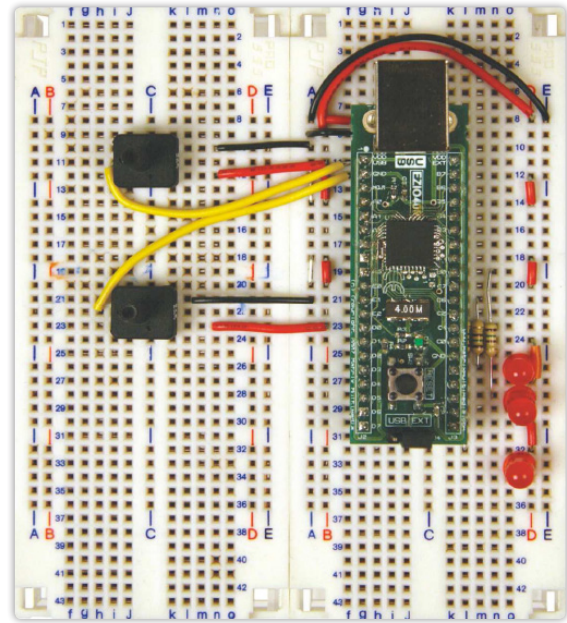

Using ECIO with a prototype board

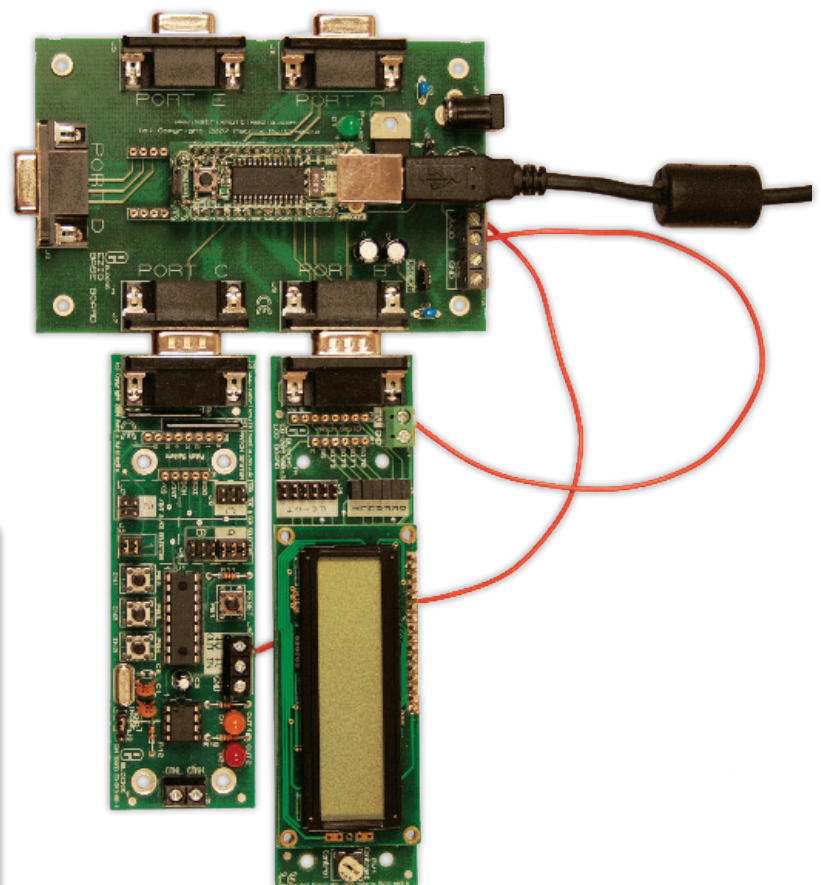

Using ECIO with E-blocks

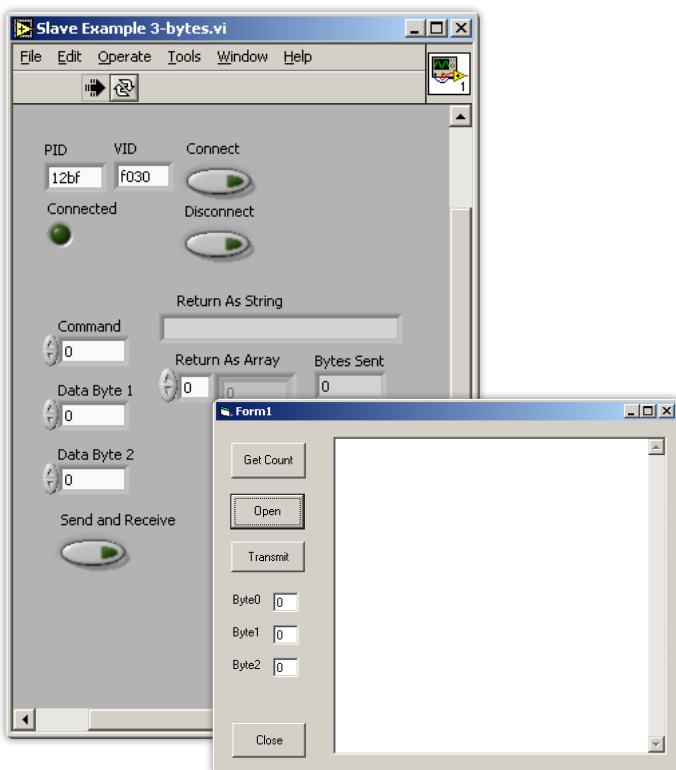

LabView and Visual Basic programs running on an ECIO



# FlowKit In Circuit Test board

The FlowKit can be connected to hardware systems to provide a real time debug facility, where it is possible to step through the Flowcode program on the PC and step through the program in the hardware at the same time. This function is available with Flowcode for PICmicro V4.2 or later.

## Benefits

- Helps to solve programming problems
- Seamless program and debug

## Features

- Compatible with PIC and ARM versions of ECIO systems via the USB lead
- Compatible with MIAC and Formula Flowcode systems via the USB lead
- Available for Flowcode for PICmicro V4.2 or later
- Allows start, step and play of programs
- Allows users to see and alter variable values

Whilst Flowcode simulation allows debug of a system to a first pass, FlowKit takes debug to a new level by running the program in the hardware and on the screen at the same time. The system is controlled from within the Flowcode environment where controls allow users to start, stop, pause and step through their program one

icon at a time. Under user control the Flowcode software shows the location of the program in the flowchart, the value of all variables in the program and allows users to alter the variable values when the program is paused.

Note that when using FlowKit with the ECIO the power jumper on the ECIO must be in the 'EXT' position so that the ECIO is powered from a separate power supply.

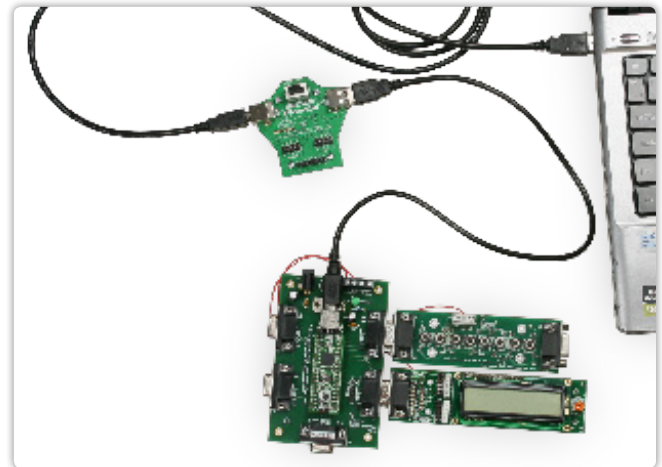

Using FlowKit with ECIO and E-blocks adaptor board

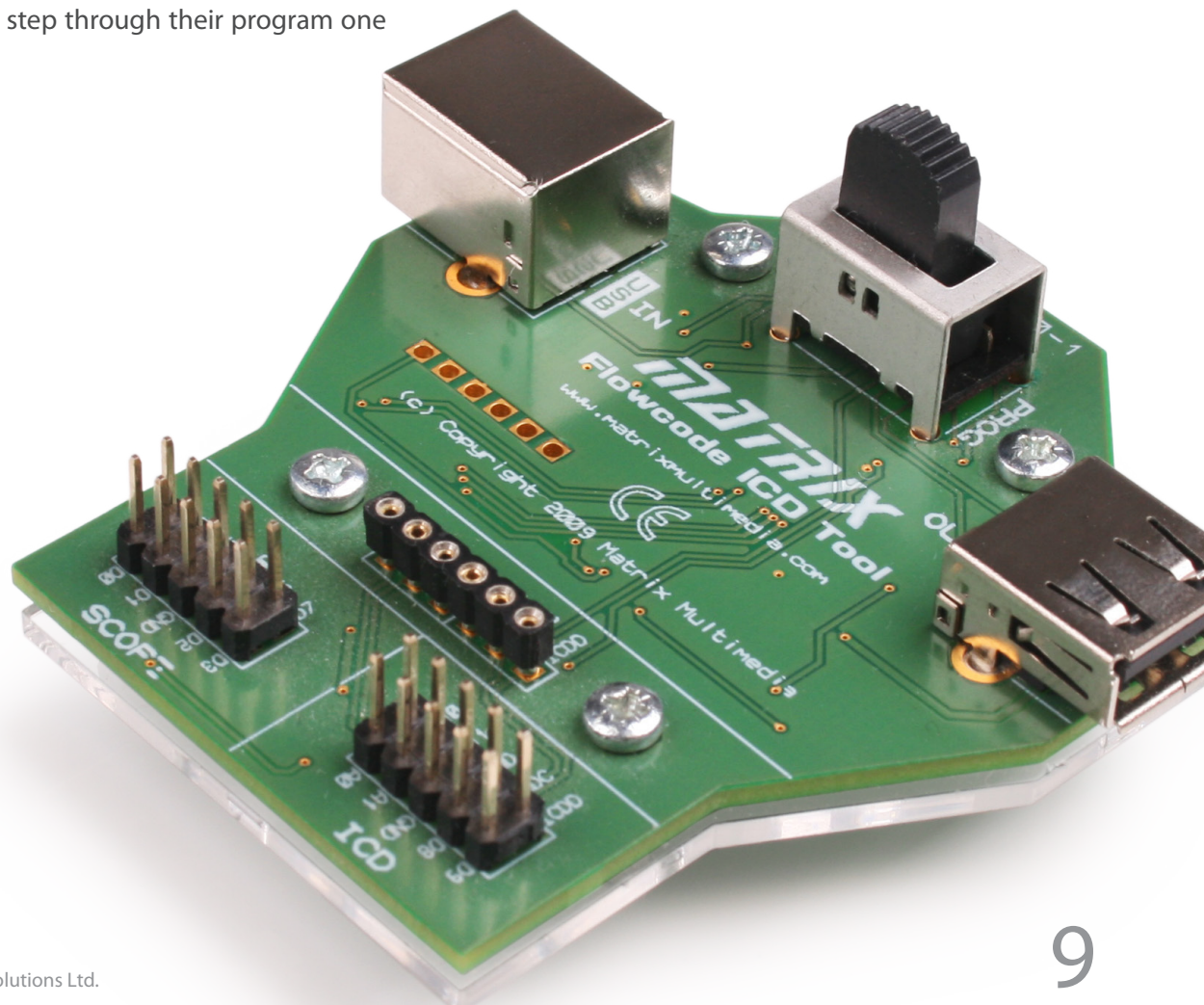

# Product codes and ordering

40 pin 18F4455 PICmicro device

ECIO40P

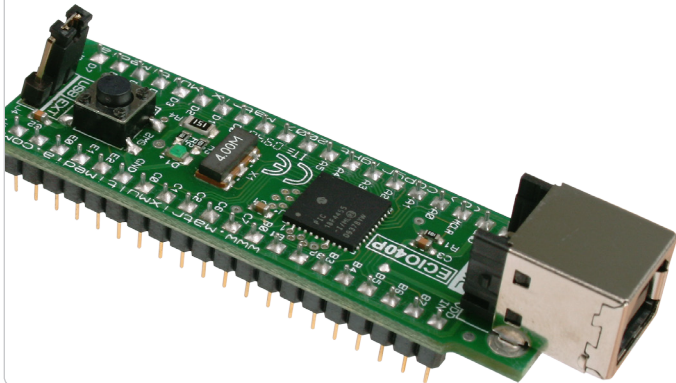

28 pin 18F2455 PICmicro device

ECIO28P

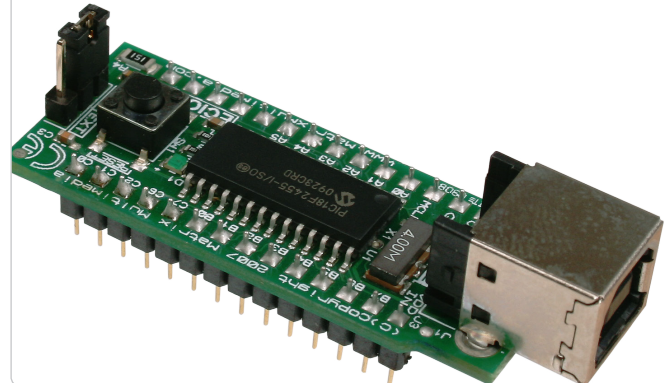

40 pin AT91 ARM device

ECIOARM

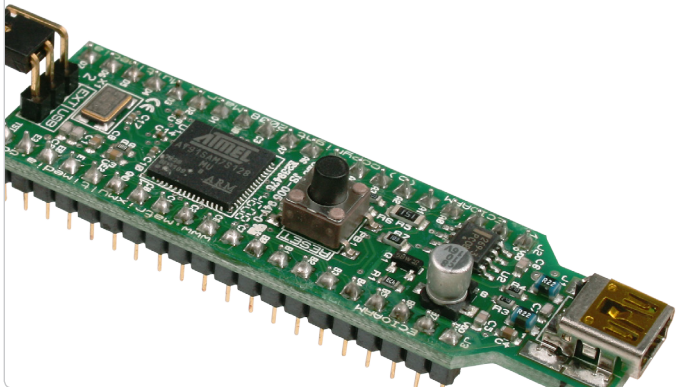

40 pin dsPIC33EP256MU806

ECIO40P16

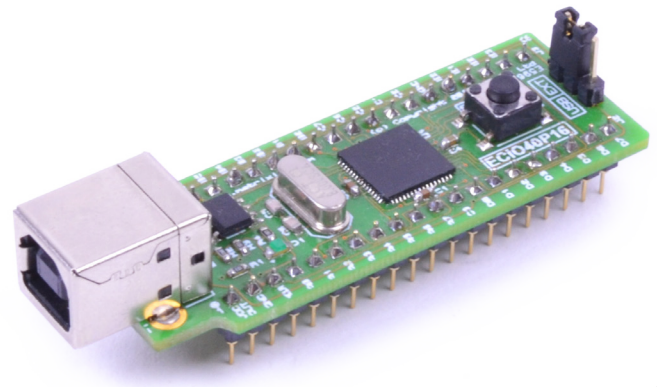

Build your own PLC bundle

EB481

The build your own PLC bundle includes an E-blocks LED board, LCD board, switch board, relay board, optoisolator board, ECIO application board, ECIO 40 pin PC board, international power supply and a full copy of Flowcode 5 for PICmicro



E-blocks application board

EB061

The E-blocks application board is compatible with all ECIO devices - both ARM and PICmicro.

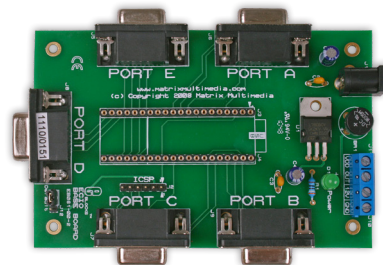

Student ECIO starter kit

EC2961

This kit is designed for students and hobbyists who want to start learning microcontroller circuit development at home. A suite of worksheets which includes build and software development instructions for 10 analogue and digital experiments are available from our website.

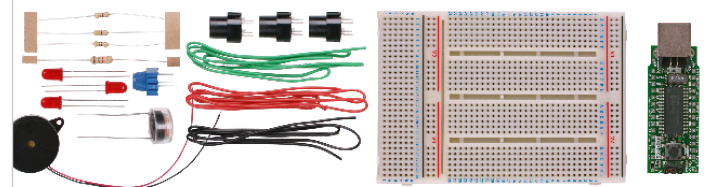



Matrix Technology Solutions Ltd.  
33 Gibbet Street  
Halifax  
HX1 5BA

t: +44 (0)1422 252380  
e: sales@matrixtsl.com

[www.matrixtsl.com](http://www.matrixtsl.com)