

EBLOCKS[®]

Motor driver board

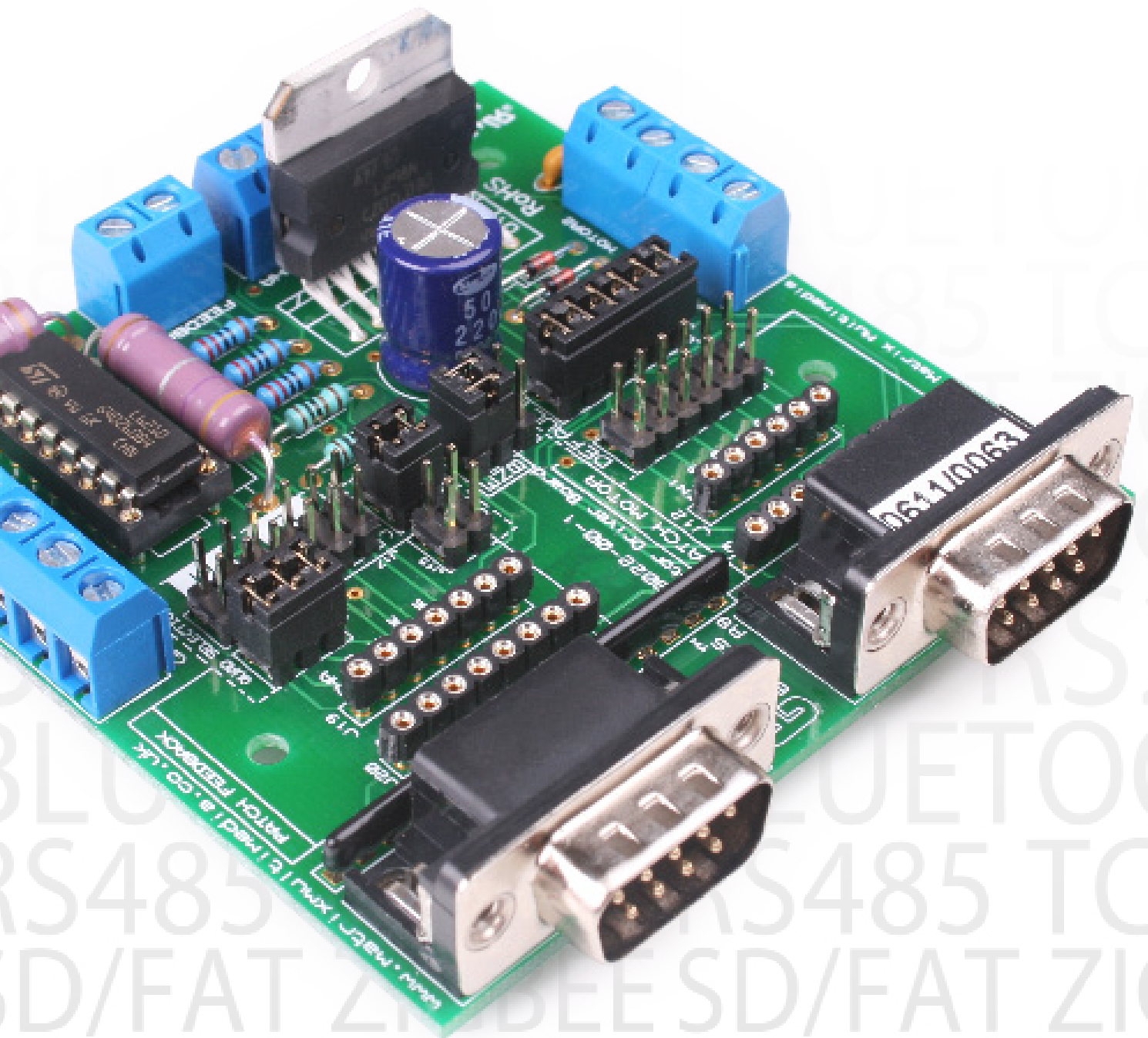

Contents

About this document	3
Board layout	3
General information	4
Circuit description	5
Circuit diagram	6

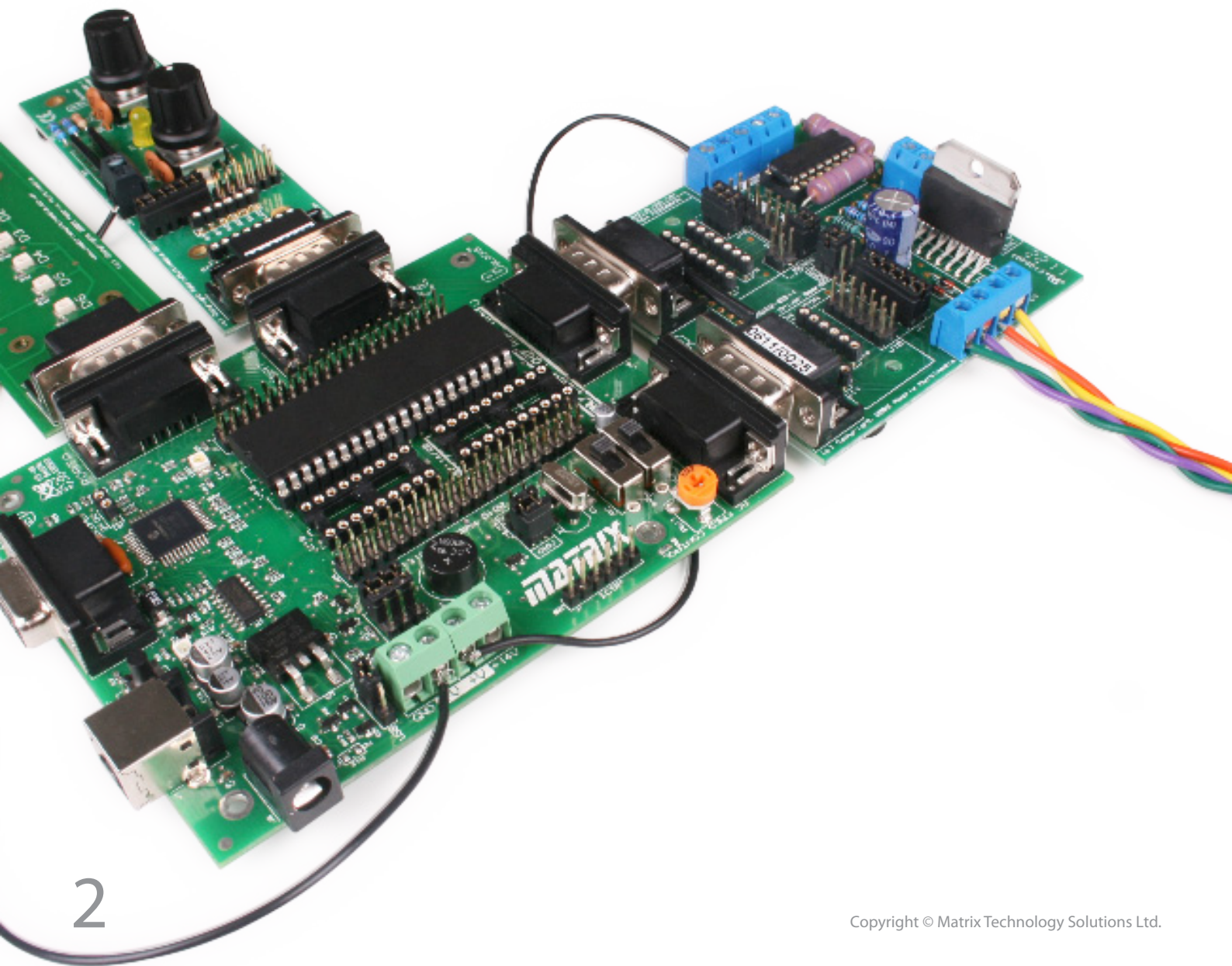

About this document

This document concerns the EB022 E-blocks motor driver board.

1. Trademarks and copyright

PIC and PICmicro are registered trademarks of Arizona Microchip Inc. E-blocks is a trademark of Matrix Technology Solutions Ltd.

2. Disclaimer

The information provided within this document is correct at the time of going to press. Matrix TSL reserves the right to change specifications from time to time.

3. Testing this product

It is advisable to test the product upon receiving it to ensure it works correctly. Matrix provides test procedures

for all E-blocks, which can be found in the Support section of the website.

4. Product support

If you require support for this product then please visit the Matrix website, which contains many learning resources for the E-blocks series. On our website you will find:

- How to get started with E-blocks - if you are new to E-blocks and wish to learn how to use them from the beginning there are resources available to help.
- Relevant software and hardware that allow you to use your E-blocks product better.
- Example files and programs.
- Ways to get technical support for your product, either via the forums or by contacting us directly.

Board layout

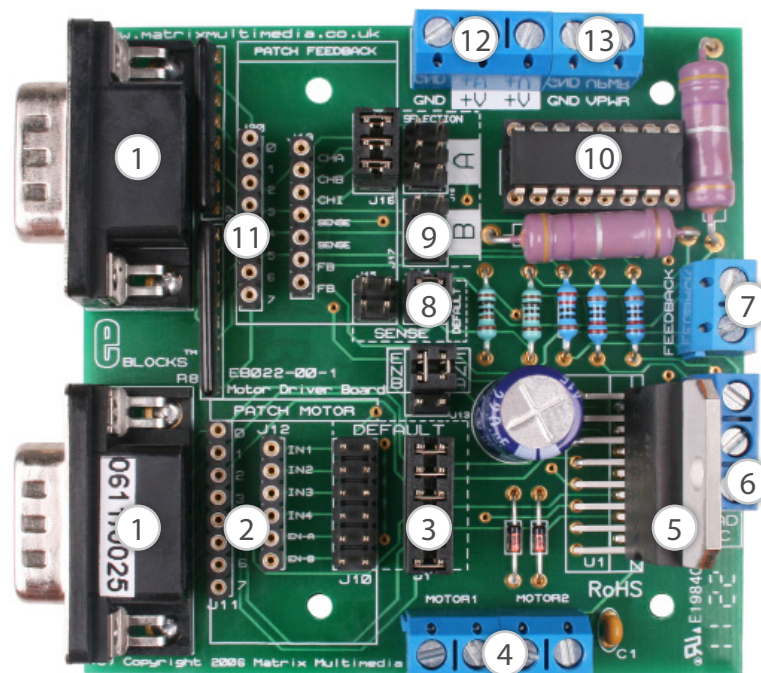

1. 9-way downstream D-type connector
2. Motor patch system
3. Motor default selection pin
4. Motor 1 and motor 2 screw terminals
5. L298 dual full bridge driver
6. Quadrature encoder screw terminals
7. Feedback screw terminals

8. Enable A / enable B selection jumper pin
9. Sense default selection jumper pin
10. L6210 monolithic IC
11. Feedback patch system
12. Power supply screw terminals
13. VPWR screw terminals

General information

The motor driver board allows the user to connect and drive two motors independently of each other. The inclusion of sense and quadrature terminals permits the user to employ feedback and positional control of the motor.

EB022 connectors	Settings
Motor jumper (J1)	Default
Enable (J13)	Refer to the first circuit diagram (page 6), enable jumper system, diagram 3
Quad	A or B
Sense (J14)	Default

NB. Ensure jumper links are positioned vertically on ENA, ENB (J13) All other jumper links are to be positioned horizontally.

NB. Ensure jumper links are positioned vertically on ENA, ENB (J13) All other jumper links are to be positioned horizontally.

Motor patch system

The motor patch system consists of one header pin connector (J10), an eight way SIL socket (J11) and a seven way SIL socket (J12). Selecting the patch default

connector (J10) permits the user to connect IN1, IN2, IN3, IN4, ENA and ENB to any of the eight connections of the D type connector.

Feedback patch system

The feedback patch system consists of a header pin connector (J18), an eight way SIL socket (J20) and a seven way SIL socket (J19). Selecting the quad patch (J18) allows the user to transmit CA, CHB and CHI signals to any of the eight connections of the feedback D type connector.

The sense patch (J15) can be used to transmit SENSE signals to any of the eight connections of the feedback D-type connector.

1. Features

- Provides the capacity to drive two motors simultaneously
- Provides independent PWM control of each motor
- Provides quadrature encoder capabilities to allow the user to sense both the position and direction of motor rotation

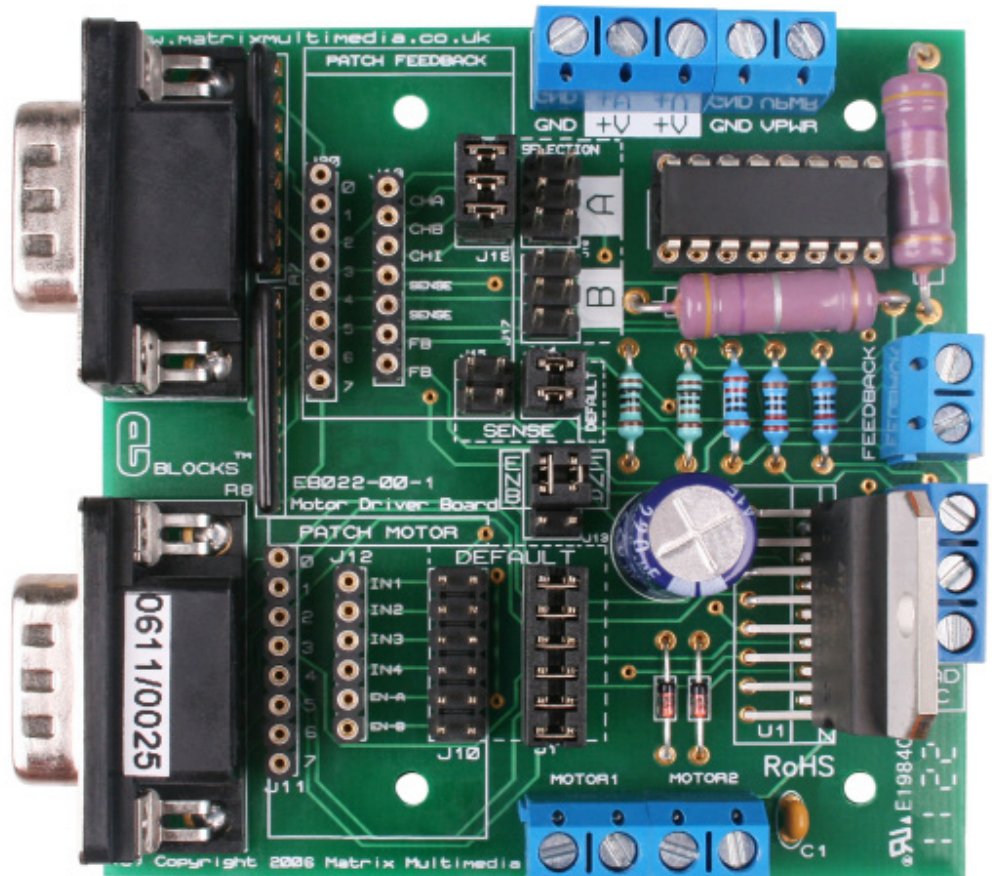

Circuit description

The EB018 motor driver circuit can be observed on page 6.

This E-block allows the simultaneous control of two independent motors using a L298 Dual Full Bridge Driver, U1. The L298 takes input logic at 3.3V or higher from an upstream E-block via J2, and provides current and voltage gain to condition the signals for driving inductive loads such as DC and stepper motors. The combination of J1 and J2 link selection blocks allow users to use the default connections (please refer to the circuit diagram) or to define their own connections to the upstream E-blocks using jumper wires. The L298 can operate at voltages up to 46V 2A peak. Care must be taken not to exceed these ratings or the L298 may be damaged.

Two enable inputs are provided to enable or disable the L298 independently of the other input signals. J13 can be wired in one of three ways: With the jumper block connectors lined up vertically, and on the top 4 connectors the enable lines are permanently connected to Vcc - always enabling the L298. With the jumper block in a horizontal position on the lower four connectors then the L298 takes its enable status from the inputs on J2.

The outputs of the L298 are connected to the L6210 which contains eight Schottky diodes arranged as two

separate diode bridges. The L6210 contains a number of diodes which clamp any induced reverse voltages from inductive loads to the ground and power rails to prevent damage to the circuit.

The terminals J4 and J5 provide terminals for motor 1 and motor 2 respectively.

Please refer to the second page of the circuit diagram:

The resistors R1 and R2 are connected between the motor load and ground via the L298. The voltage across R1 and R2 is proportional to any current flowing through the motor and can therefore be used to sense the motor load or work rate. The two zener diodes clamp the resulting voltage to 3.3V to prevent high voltages being passed back to the upstream board.

The screw terminal connector J21 allows quadrature feedback to be passed back to the controlling circuit via a patch and link block system. The screw terminal j& allows an additional input signal to be incorporated into your system. Resistors R7 and R8 provide protection for the upstream device.

3.3V operation

This board is compatible with upstream boards operating off 3.3V.

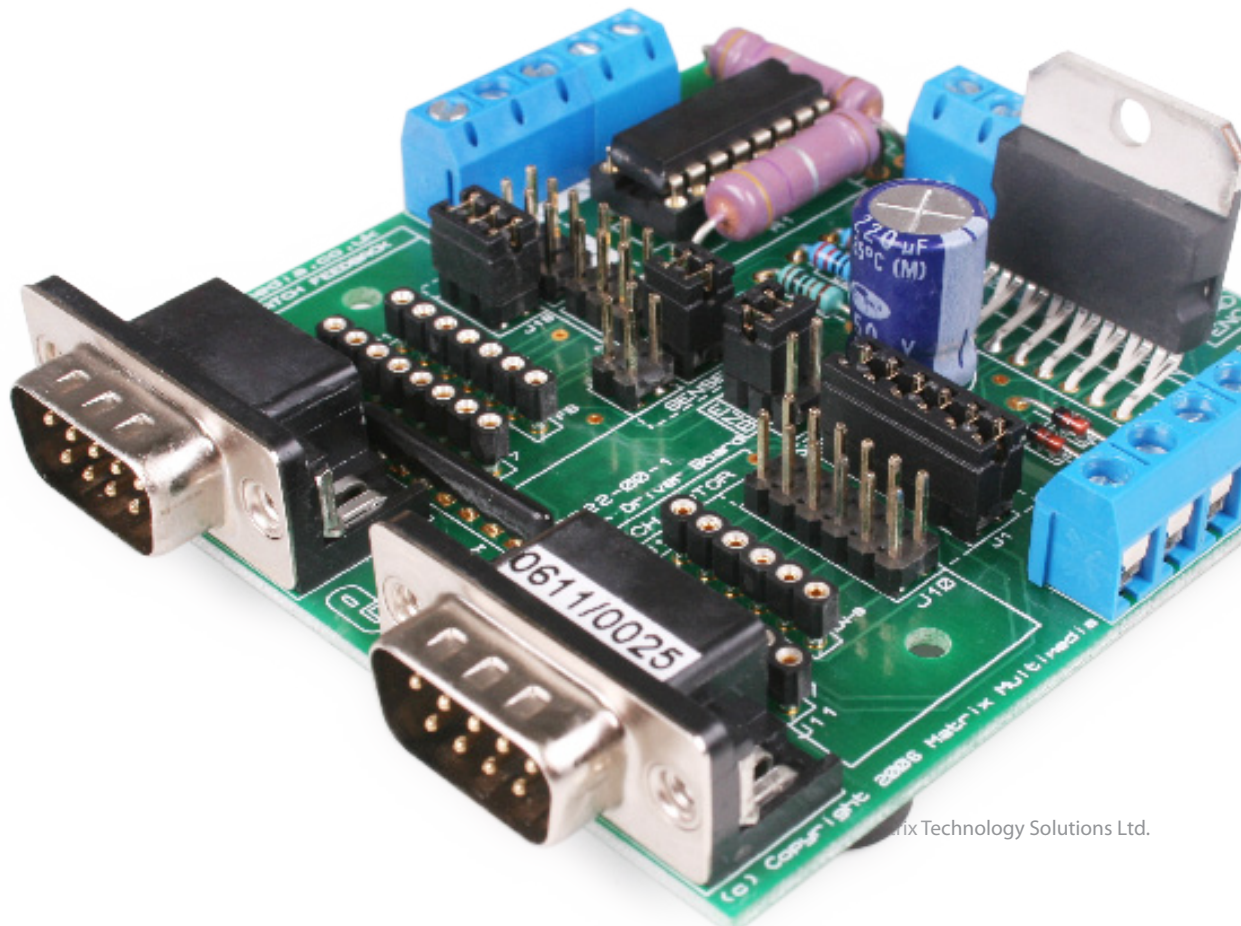

Circuit diagram

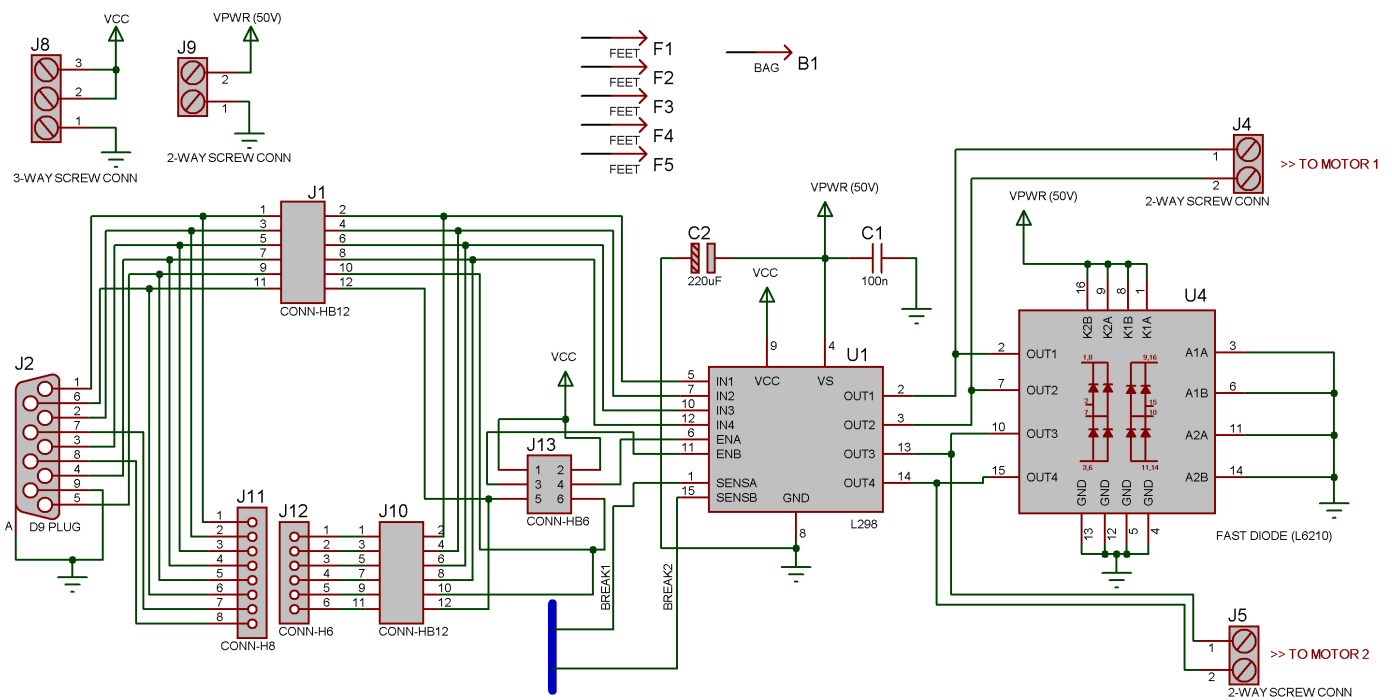

Enable jumper system

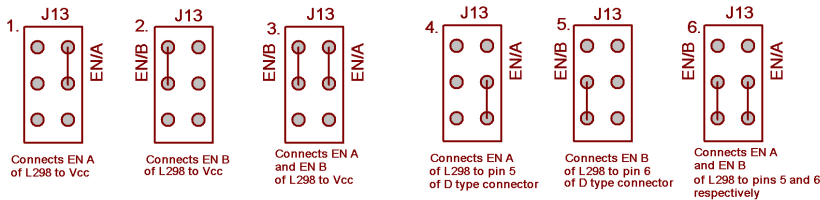

The above diagrams are for reference only.



Matrix Technology Solutions Ltd.
The Factory
33 Gibbet Street
Halifax, HX1 5BA, UK

t: +44 (0)1422 252380
e: sales@matrixtsl.com

www.matrixtsl.com

EB022-30-2